

For Commissioning see Installation & Servicing instructions.
For more information visit: support.mixerly.co.uk

1.	Site cylinder and check clearances
2.	Plumbing and pipework
3.	Fit Mixerly gauge
4.	Install and connect to household wiring
5.	Make connection to router
6.	Commissioning
7.	Complete the Benchmark installation form in manual

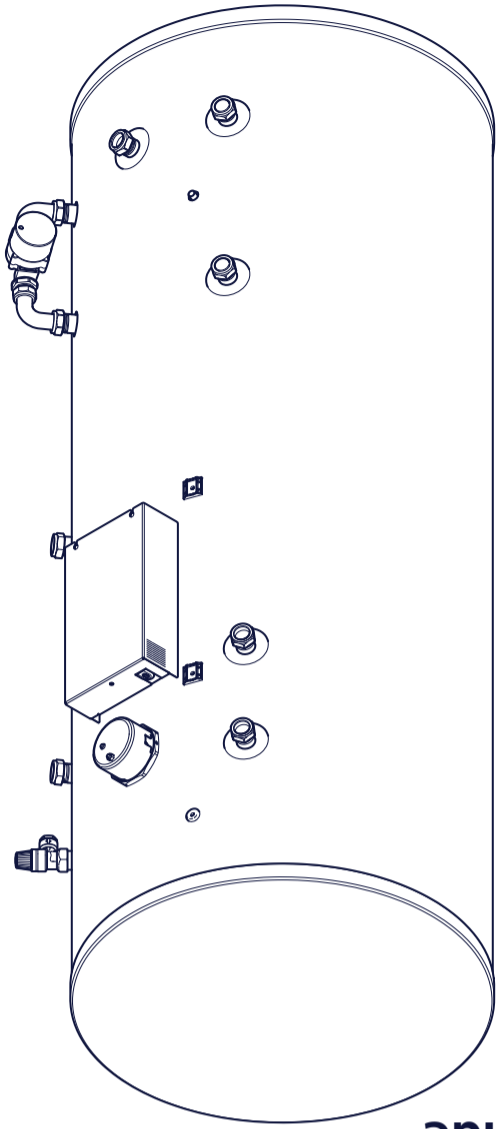

Please read in full before starting installation and refer where necessary to main Installation & Servicing instructions.



Mixerly X
For stainless steel hot water cylinders
Quick-fit Guide

5. Checklist

1. Schematics

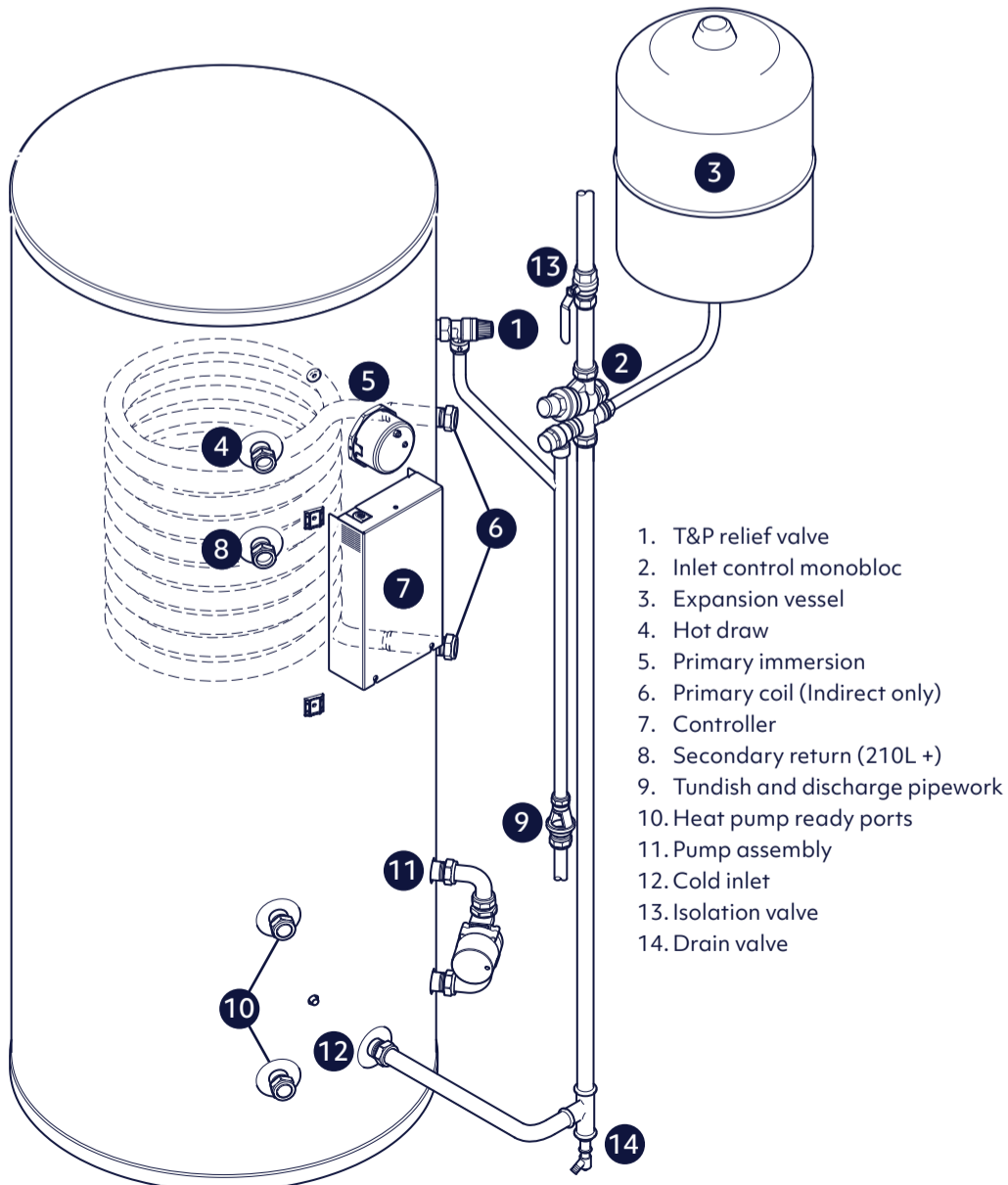

Direct unvented

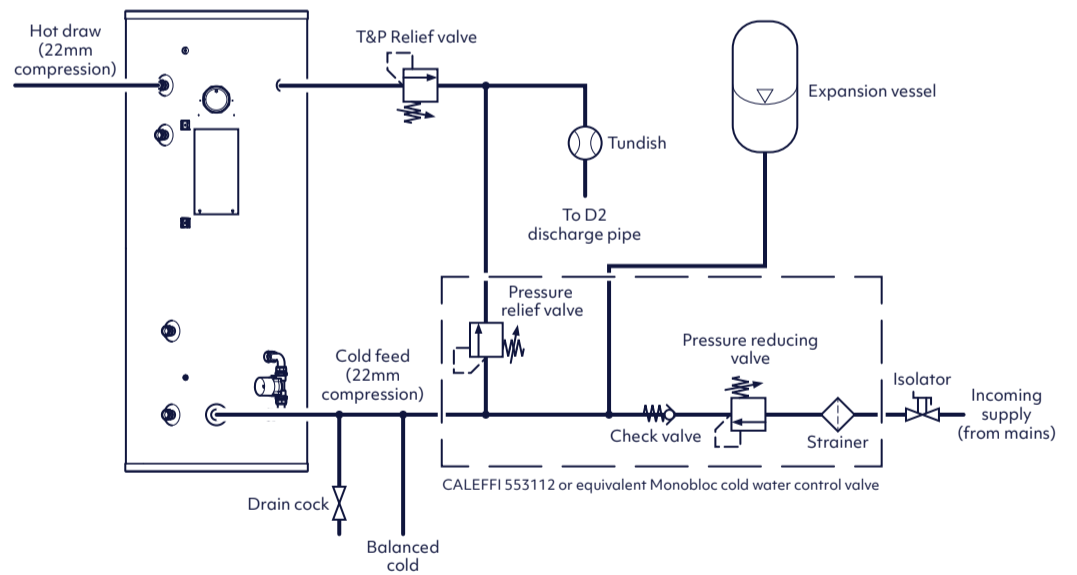

Indirect unvented

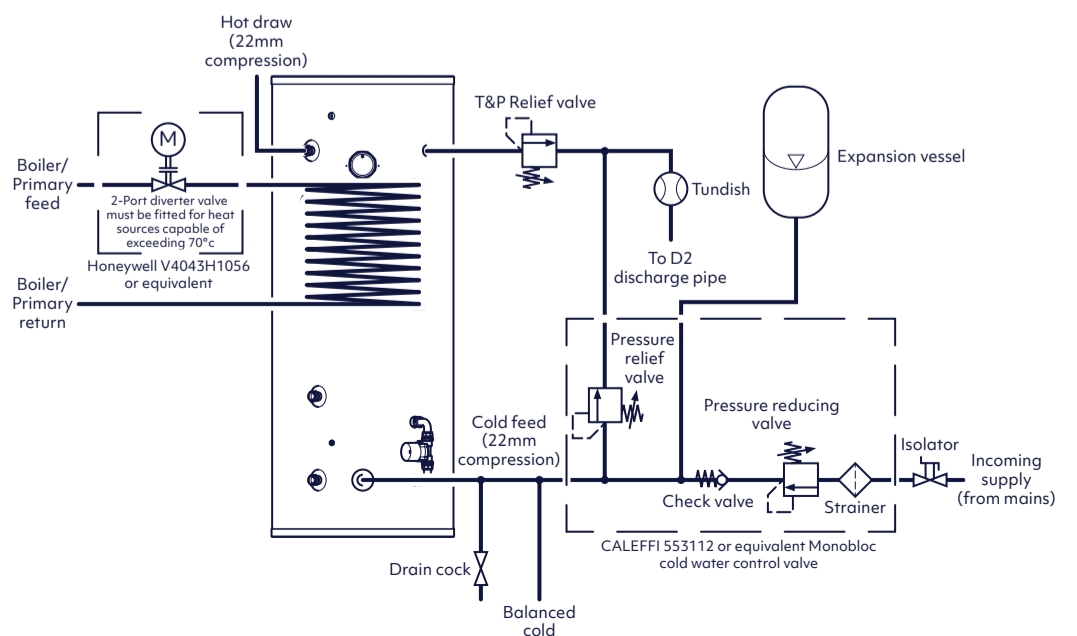

2. Installation - Plumbing



Site requirements
Ensure all clearances are met

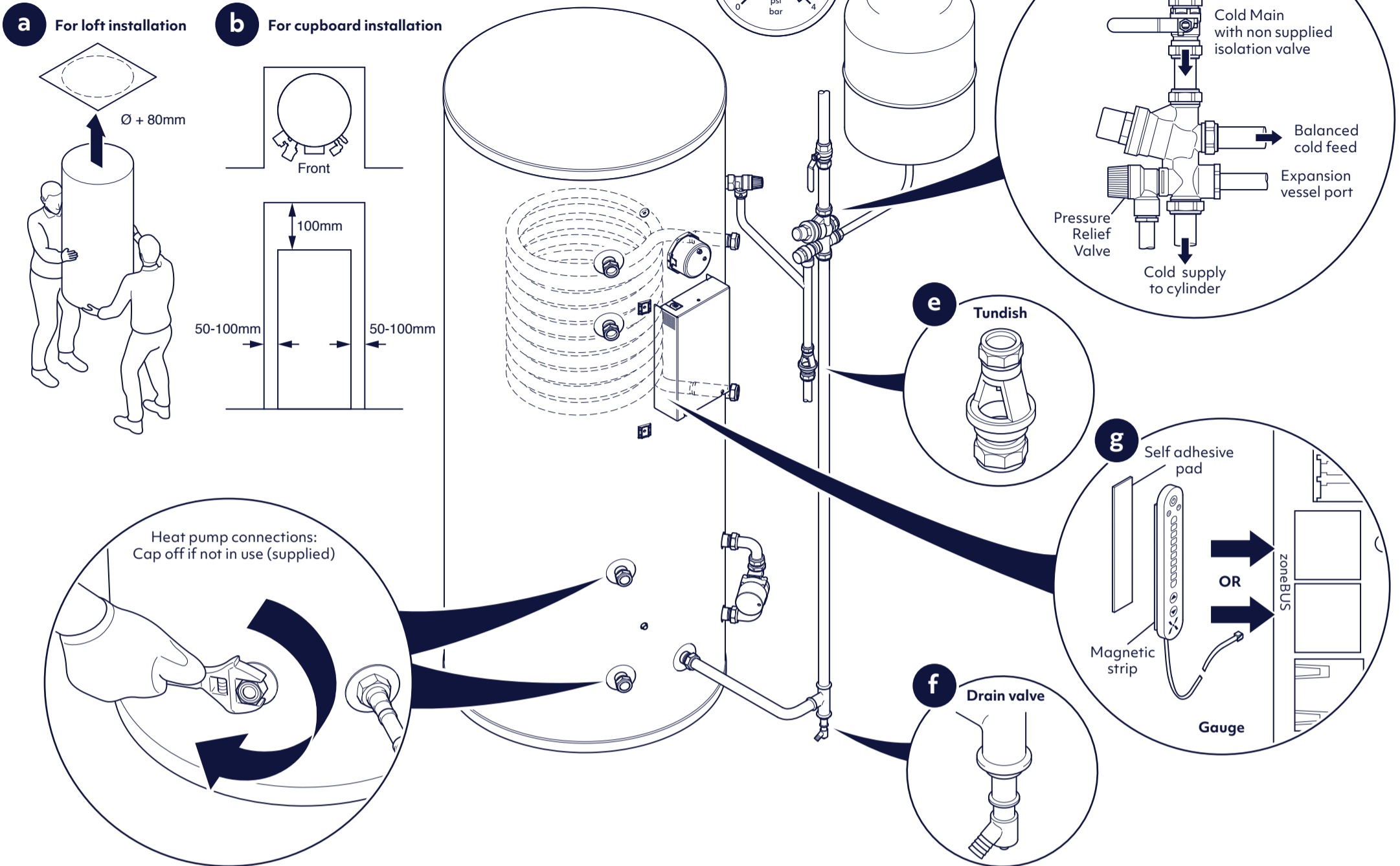

3. Installation - Wiring

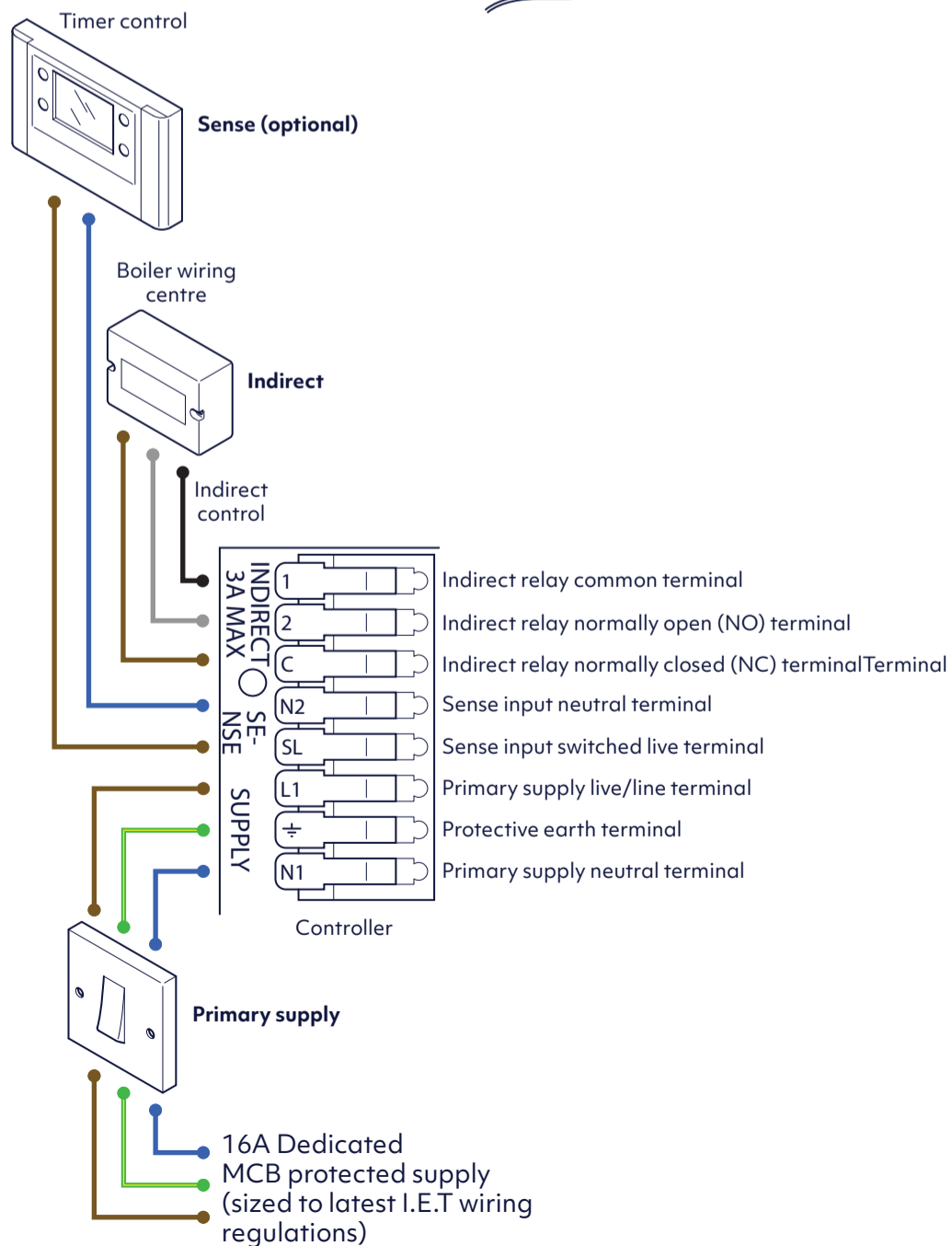

4. Connectivity



Set up for the cylinder to be connected by homeowner using the provided WIFI dongle (a) or by hard-wired ethernet (b)

