

Mixergy iHP

Installation & Servicing instructions

For R290 stainless steel integrated heat pump cylinders

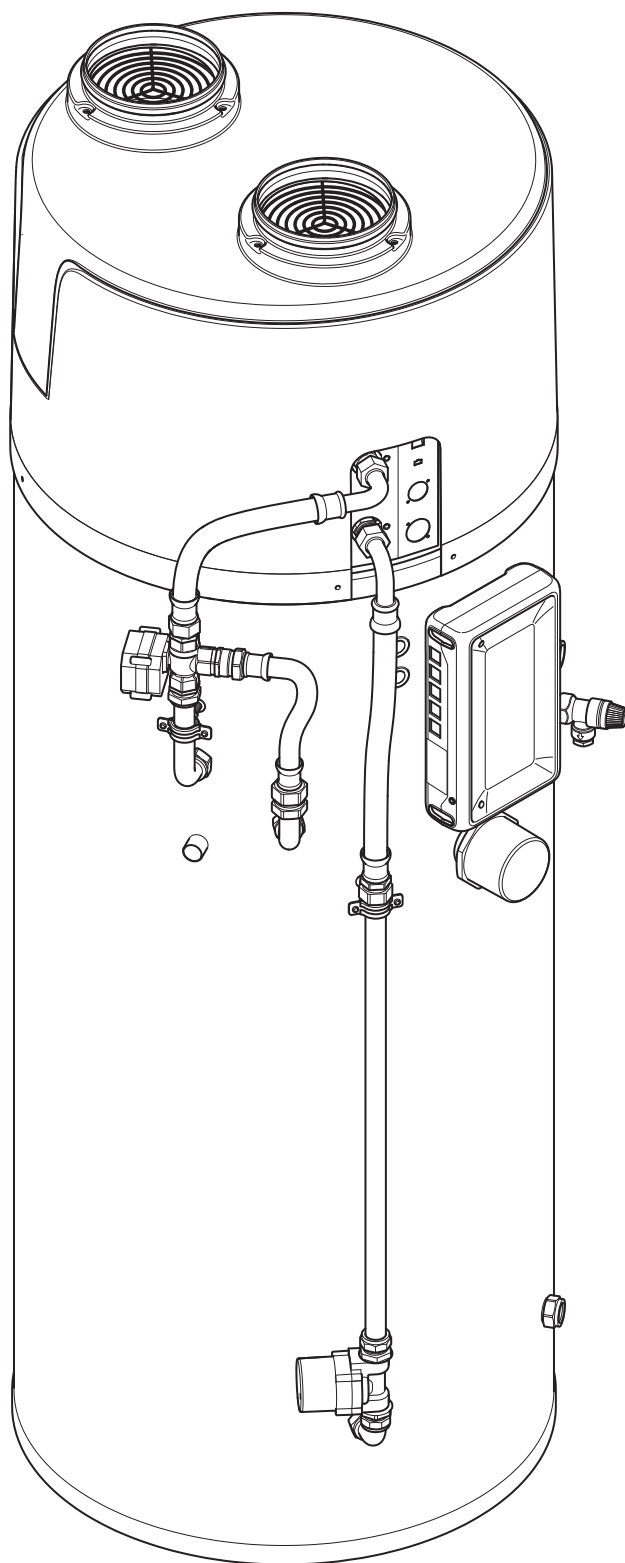

PLEASE LEAVE WITH HOUSEHOLDER

Failure to install and maintain this system in accordance with these instructions will invalidate the manufacturer's warranty.

mixergy[®]

Contents

1.0	Cylinder details - MX number	6
2.0	Technical data	6
3.0	Safety	7
4.0	Performance	8
5.0	Additional components	9
6.0	Design notes	10
7.0	Schematic	11
8.0	Hydraulic schematics	12
8.1	Direct unvented	12
9.0	Installation: general guidelines	13
9.1	Positioning of the cylinder	13
9.2	Unvented installations	14
9.3	Pipework and cold water inlet control group	14
9.4	Fitting a drain valve	14
9.5	Positioning the tundish	15
9.6	Checking the pump and T&P relief valve	15
9.7	Fitting the expansion vessel	15
10.0	Installation: Heat Pump Head Unit	16
10.1	Check condensate sealing cap is fitted	16
10.2	Assembling the head unit onto the cylinder	16
10.3	Heat pump supply and immersion connections	17
10.4	Heat pump data connections	17
11.0	Installation: Heat Pump Head Unit Pre Plumb Kit	18
11.1	Connect the Full Circulation Return Assembly	18
11.2	Connect the Top Up Return Assembly	18

Contents

11.3	Fit Head Unit Feed Assembly	19
11.4	Valve Electrical Connection	19
11.5	Pre-plumb pipework insulation	19
12.0	Installation: Heat Pump Head Cover	20
12.1	Installing the top cover	20
12.2	Head Unit Sealing	20
13.0	Installation: Heat Pump Ducting	21
13.1	Ducting Design	21
14.0	Building Regulation G3 Discharge Requirements	24
14.1	Discharge pipes from safety devices	24
14.2	Tundish	24
14.3	Discharge Pipe D2	24
15.0	Discharge pipework	25
15.1	Typical discharge pipe arrangement	25
15.2	Sizing of discharge pipe D2 for common temperature relief valve outlet sizes	25
15.3	Discharge pipe D2	26
15.4	Termination of discharge pipe	27
15.5	Termination of condensate hose	27
16.0	Fitting the gauge	27
17.0	Installation: electrical	28
17.1	Indirect units and electrical wiring	28
17.2	External wiring	28
17.3	Primary supply (13A, 230-240V~, 1.5mm ² CSA)	28
17.4	Timer control (VOLT-FREE, 10mA 80-240V~, 0.5mm ² CSA)	29
17.5	Wiring diagram	29

Contents

18.0	Installation: connectivity	30
18.1	Installing the powerline adaptor	30
18.2	Wiring an ethernet connection	31
19.0	Current reader kit installation (option)	32
19.1	Overview	32
19.2	Included parts - MAS0071 single current clamp kit	32
19.3	Positioning the CT interface	32
19.4	Installation of the current clamp	33
19.5	Connection of the CT interface to the controller	33
19.6	Controller connector positions	34
20.0	Commissioning	35
20.1	Fill and bleed the system	35
20.2	Changing heating mode	37
20.3	Status LED error codes	37
20.4	Pairing the cylinder and connecting to the internet	38
20.5	Commissioning checklist	39
21.0	Problem solving	41
21.1	Overheated water	41
21.2	Water discharge	41
21.3	Electrical fault	41
21.4	Connectivity issues	41
21.5	Expansion vessel check and re-charging	41
21.6	Safety valves	42
21.7	Immersion heaters	42
22.0	Draining the cylinder	43

Contents

22.1	Flushing the cylinder	43
23.0	Replacement parts	43
24.0	Guide to safe isolation	45
25.0	Servicing and maintenance	46
25.1	Annual service checks	46
25.2	Disassociating an account	46
25.3	De-scaling	46
26.0	Service record	48

1.0 Cylinder details - MX number

Your cylinder MX number can be found on the label placed on the front of the cylinder.

For all queries, please visit:

support.mixergy.co.uk

Model code	MX-180-ELE-EXT-550-1-1-A
Total weight	227 kg (wet), 54 kg (dry)
Immersion heater rating	230-240 V~ 2.7-3.0 kW
Immersion heater type	1 3/4" BSP – 400mm Incoloy
Standing heat loss/24 hr	1.8 kWh
Heat exchanger rating	-- kW
Max. supply pressure	1 MPa (10 bar)
Expansion relief pressure	0.6 MPa (6 bar)
Max. operating pressure	0.55 MPa (5.5 bar)
Max. coil pressure	0.35 MPa (3.3 bar)

MX000000	
Scan the QR code to add your tank to your account or visit www.mixergy.io/register	
mixdevice-aaaaa-bbbbb-cccc--ddddd-eeee	



Fig. 1

2.0 Technical data

Max. supply pressure to pressure reducing valve	10 bar
Operating pressure	3 bar
Expansion vessel charge pressure	3 bar
Expansion relief valve setting	6 bar
P&T relief valve setting (pressure)	7 bar
P&T relief valve setting (temperature)	90 °C
Thermostat safety cut-out temperature	80 °C
Adjustable temperature range (Head unit only)	45 - 65 °C (59 °C)
Coil max. working pressure (indirect)	3.5 bar
Heat Pump Consumption (Cont.)	230-240 V~ 550W
Heat Pump Rating	1.5kW
Refrigerant (Charge)	R290 (150g)

3.0 Safety



This equipment must be connected to a protective earthing (PE) conductor.



This equipment is designed for connection to single phase supplies with the neutral conductor at earth potential – category TN or TT. This equipment is not designed for use with live and neutral connections reversed or where the neutral conductor is not at earth potential (IT supplies).

This device must be connected via a 16A MCB protected supply.

Always disconnect the device from the supply before removing or replacing the cover. This device has been manufactured in accordance with current safety standards. However, incorrect operation or misuse may result in:

- Injury or death to the operator or third parties.
- Damage to the device and other property of the operator.
- Incorrect operation of the device.

All persons involved in commissioning, maintaining, and servicing the device must:

- Be suitably qualified and competent.
- Have knowledge of and experience in dealing with electrical installations.
- Read and follow these operating instructions carefully.



Unvented hot water cylinders must not be used with solid fuel boilers as the energy source. All models are factory fitted / supplied with immersion heaters that have built-in thermal cut-outs. Heaters without thermal cut-outs must not be fitted. All unvented installations must be fitted with a pressure reducing valve (supplied) and P&T relief valve (fitted). These must not be removed or used for any other purposes than what they are designed for.

4.0 Performance

Product code	MX-120-IH2-579	MX-150-IH2-579	MX-180-IH2-579	MX-210-IH2-579	MX-250-IH2-579
Nominal capacity (litres)	120	150	180	210	250
Expansion vessel size	12L	12L	19L	19L	19L
Standard heat loss * (kWh/24hr)	0.54-1.06	0.54-1.22	0.54-1.34	0.54-1.44	0.54-1.75
Back-up heater rating (kW)	2				
Coefficient of performance (CoP)	3.4				
Minimum reheat time (15-50°C)	30mins	30mins	30mins	30mins	30mins
70% Charge reheat time (15-50°C)	83mins	103mins	123mins	144mins	172mins
100% Charge reheat time (15-50°C)	118mins	147mins	176mins	205mins	255mins

Cylinder material	Duplex stainless steel
Refrigerant	R290
Air operating range	-7°C to +35°C
Achievable hot water temperature via heat pump	59°C
Heat pump electrical rating (kW)	0.55
Heat pump max. power output (kW)	1.5
Sound power (dB)	50
Airflow (m ³ /hr)	500
Air duct diameter (mm)	150
Water connections	22mm compression
Electrical supply	13A, 230-240V

* Standing loss is given in Watts at 100% charge, for SAP calculations this can be converted to kWh/24hr by multiplying by 0.024.

5.0 Additional components

- Monobloc cold water inlet control group including pressure reducing valve, check valve, pressure and temperature relief valve and expansion relief valve (unvented only)

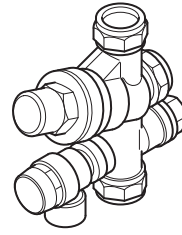

- Tundish (unvented only)



- Expansion vessel including mounting bracket and 3/4" x 22mm adaptors (unvented only)

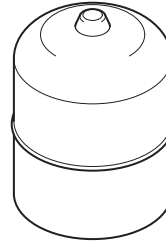

- 2 kW immersion heater(s) 1.3/4" BSP (factory fitted)

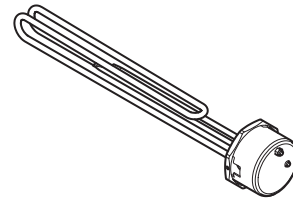

- Powerline to ethernet adaptor TL-PA4010

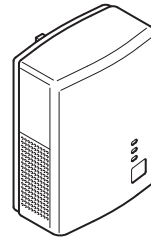

- Ethernet cable

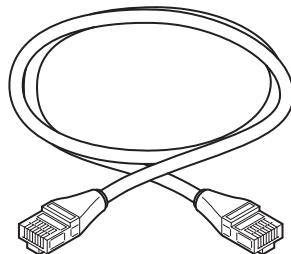

- User guide

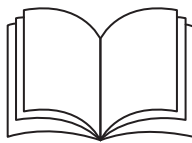

- Gauge

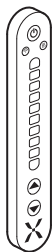

Optional components

- MAS0071 accessory kit:
 - Current clamp interface MK2 (MAS0196) x1
 - SCT-16 current clamp (MEC0029) x1
 - Mounting hardware (VHB pad, screws x2, wall plugs x2)
 - 1m ethernet cable x1, 2m ethernet cable x1

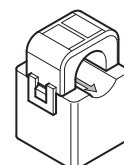
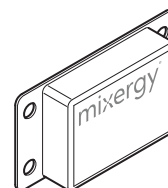

6.0 Design notes



Installers must be appropriately qualified to install unvented hot water cylinders as per G3 regulations.

All models are factory fitted / supplied with immersion heaters that have built-in thermal cut-outs. Immersion heaters without thermal cut-outs must not be fitted.

All unvented installations must be fitted with a pressure reducing valve (supplied) and P&T relief valve (fitted). These must not be removed or used for any other purposes than what they are designed for.

The unit is supplied in two parts (the cylinder and the top mounting heat pump) to ease installation.

Both parts should be handled with care in order to avoid damage.

They should be stored upright in a dry place.

The cylinder and heat pump should be carried upright where possible.

Assessments of risks for carrying both parts of the unit should be conducted.

Use more than one person for carrying where appropriate.

- Never carry the cylinder using the components.
- If it is necessary to remove the heat pump from its shipping pallet then remove the cover and use the two lifting handles. Under no circumstances lift using the internal pipework.

Always follow the latest guidelines for lifting techniques to avoid injury or damage to the product.

7.0 Schematic

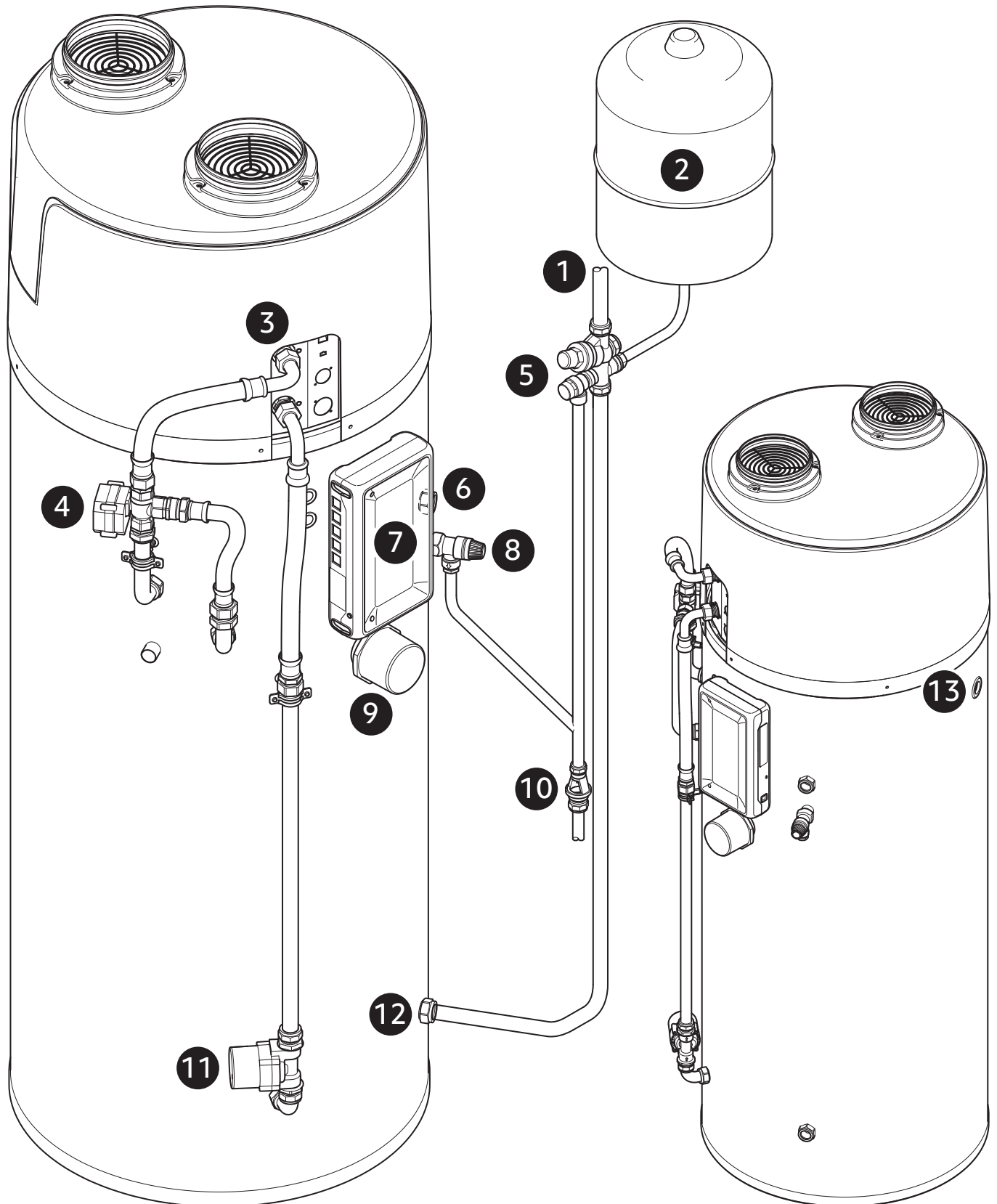

Fig. 3

- | | | | |
|----|------------------------------|-----|--------------------------------|
| 1. | Cold water feed | 8. | T&P relief valve |
| 2. | Expansion vessel | 9. | Back-up immersion |
| 3. | Heat pump head unit | 10. | Tundish and discharge pipework |
| 4. | Circulation mode valve | 11. | Pump assembly |
| 5. | Cold water combination valve | 12. | Cold water inlet |
| 6. | Hot water draw off | 13. | Condensate drain |
| 7. | Controller | | |

8.0 Hydraulic schematics

8.1 Direct unvented

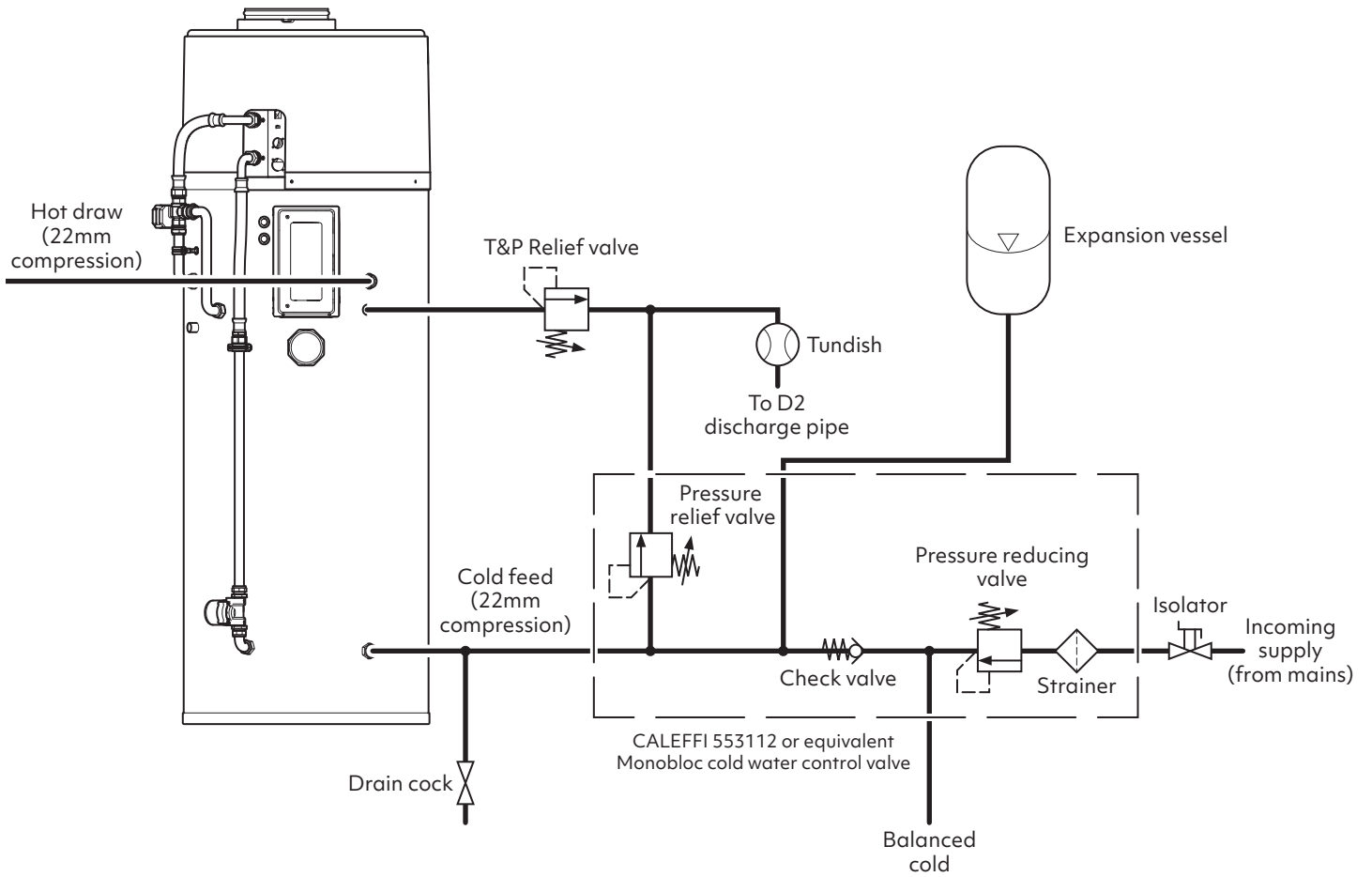

Fig. 4

9.0 Installation: general guidelines



Installation of the appliance must be carried out by a qualified engineer in accordance with prevailing and national regulations as listed below:

Building Regulations G3

The Building Standards (Scotland)

The Building Regulations (Northern Ireland)

I.E.T. Electrical Regulations (Latest edition thereof)

UK Water Regulations

The installation area should be able to cope with the weight, incoming pipes and discharge pipe when full.

9.1 Positioning of the cylinder

Position of the cylinder should suit the installation; all connections should be to the front for ease of access.

Ensure suitable space is left for access for repair and/or replacement of immersions and valves etc.

For further guidance, please refer to the ducting template (supplied).

Leave at least 350mm of vertical clearance above the cylinder from the top of the ducting spigots. This must include removable sections of ducting to allow for easy removal of the top cover.

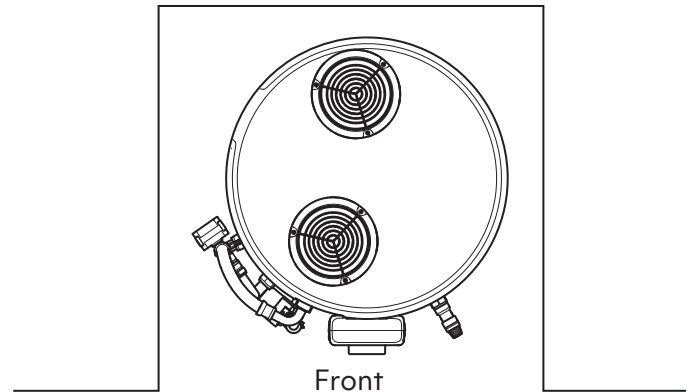
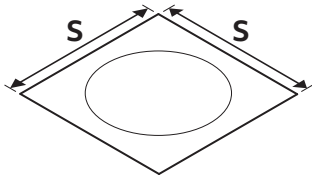

Fig. 5

Model	120L	150L	180L	210L	250L
Height	1325mm	1515mm	1695mm	1885mm	2145mm
Diameter	580mm	580mm	580mm	580mm	580mm
Weight empty	83kg	86kg	90kg	94kg	97kg
Weight full*	203kg	236kg	270kg	304kg	347kg

9.0 Installation: general guidelines



Ensure that any apertures (such as loft hatches) that the cylinder must pass through, meet the minimum space requirement S.

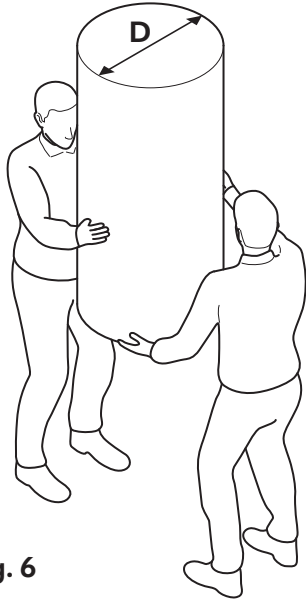

Fig. 6

Nominal diameter D	Space requirement S
580mm	700mm

9.2 Unvented installations

In the case of an unvented installation, installers should ensure incoming mains pressure is less than 10 bar and at-least 1 bar with a minimum flow rate of 10 L/min.

9.3 Pipework and cold water inlet control group

The unit should be piped in with a nominal 22mm pipe to ensure adequate flow rate. The unit is supplied with a monobloc pressure reducing valve that has a set pressure of 3 bar. The valve also consists of a serviceable strainer, non-return valve, expansion relief valve, connection for an expansion vessel and balanced cold feed supply. We would strongly recommend fitting an isolating valve (not supplied) prior to the monobloc valve for ease of maintenance at a later date.

Under no circumstances should an isolating valve be fitted between the expansion valve and the storage cylinder.

9.4 Fitting a drain valve

Please ensure that a drain valve is fitted to the lowest part of the pipework installation.

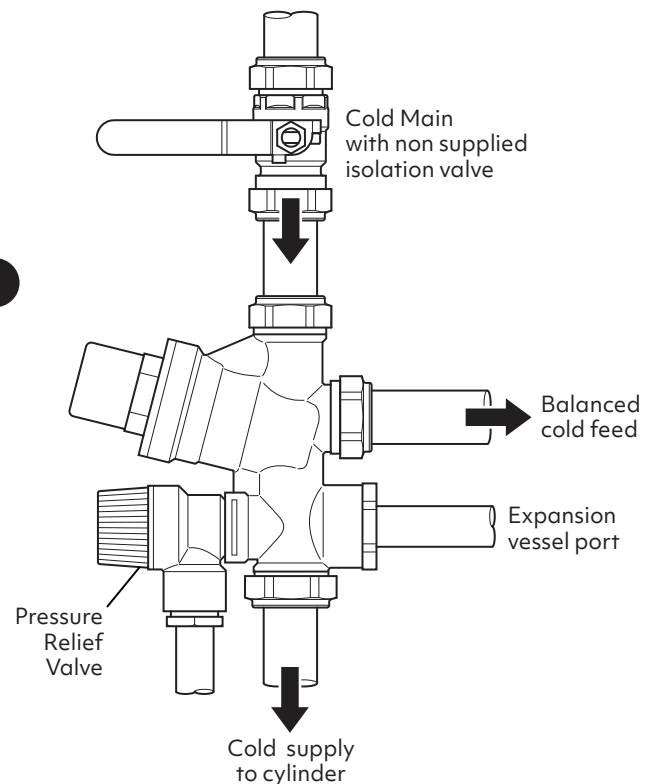

Fig. 7

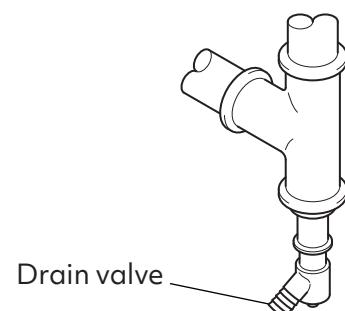

Fig. 8

9.0 Installation: general guidelines

9.5 Positioning the tundish

The tundish, which shows visible discharge from the relief valves, is to be in a prominent, visible and safe position away from any electrical devices. See 14.1 Discharge pipes from safety devices on page 24.

9.6 Checking the pump and T&P relief valve

The temperature and pressure relief valve is set at 7 bar and 90°C. Both the pump and T&P valve are factory fitted and sealed prior to dispatch. Whilst we endeavour to make sure there are no leaks from these seals, we would advise checking the connection as the valve/pump may have been disrupted in transit.



The pump body is plastic. Use two spanners when tightening the pump compression glands to avoid cracking the pump body

9.7 Fitting the expansion vessel

The expansion vessel should be checked and if required charged at 3.0 bar.

The vessel should be mounted securely to the wall or sufficient support with the fixing kit supplied.

The connection should be made between the vessel and monobloc kit using the included 3/4" x 22mm compression adaptor.



The relief valves are only to be used for relief discharge purposes. No valves should be fitted between the relief valves and the cylinder.



The electrical supply to the controller must be installed by a qualified electrician.



Ensure that any apertures (such as loft hatches) that the cylinder must pass through, meet the minimum space requirement S (see page 12 for details)

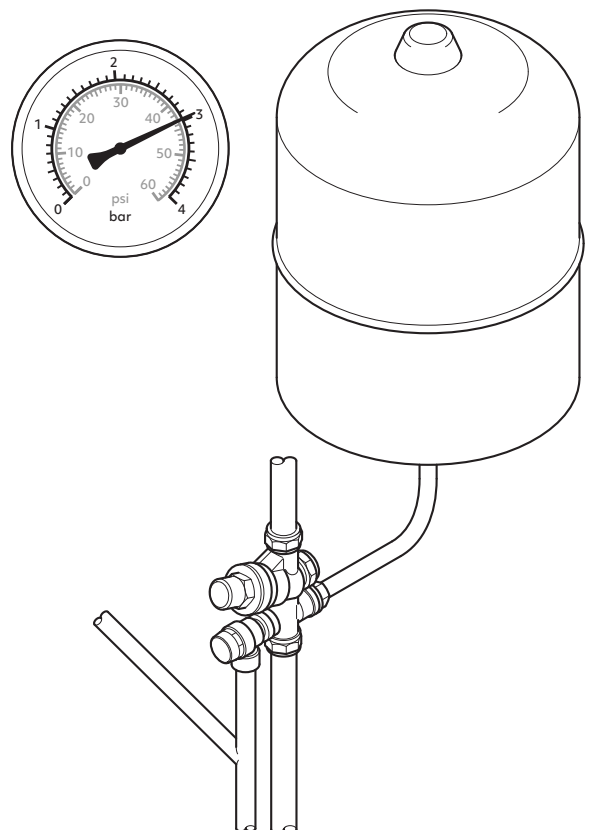

Fig. 9

10.0 Installation: Heat Pump Head Unit

10.1 Check condensate sealing cap is fitted

The central hole in the condensate tray **must** be fitted with the sealing cap to prevent water ingress to the cylinder insulation. Before fitting the heat pump head unit check that this is in place.

If the cap is missing a spare is included in the installer kit.

This **must** be fitted before mounting the head unit.



If the sealing cap is not installed before the cylinder is commissioned this will invalidate the cylinder warranty.

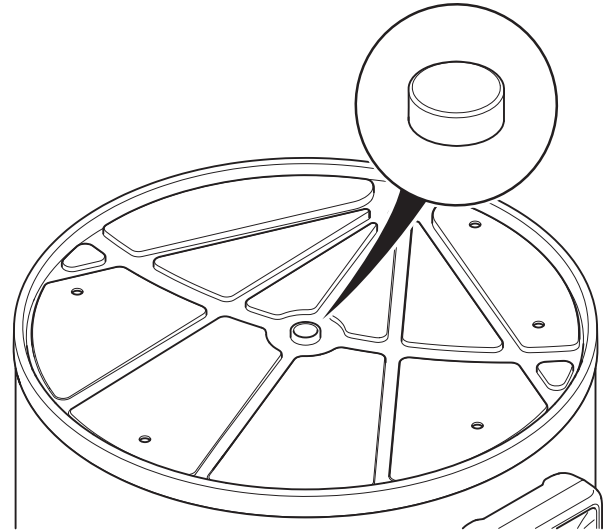

Fig. 10

10.2 Assembling the head unit onto the cylinder

The head unit and cylinder are delivered separately to simplify installation.

Once the cylinder is in position the head unit can be lifted onto the top of the cylinder ensuring that the hydraulic connections line up with the head unit feed assembly and that the threaded inserts in the condensate tray line up with the fixing holes.



Fix the head unit to the cylinder using the four M8x25 bolts and M8 washers provided.

The head unit weighs 33kg so requires two people to lift safely. There are two lifting loops at the front of the head unit: one on the compressor, and one on the plate heat exchanger. Remove the cover to access these. Lift using these, steadying the unit using the fan and electronic housings.

DO NOT lift by the refrigerant pipe work as this may damage the head unit and will void the warranty.

1. Fan housing
2. Electronics housing
3. Compressor
4. Compressor lifting handle
5. Plate heat exchanger
6. Plate heat exchanger lifting handle
7. External connection panel
8. Condensate tray

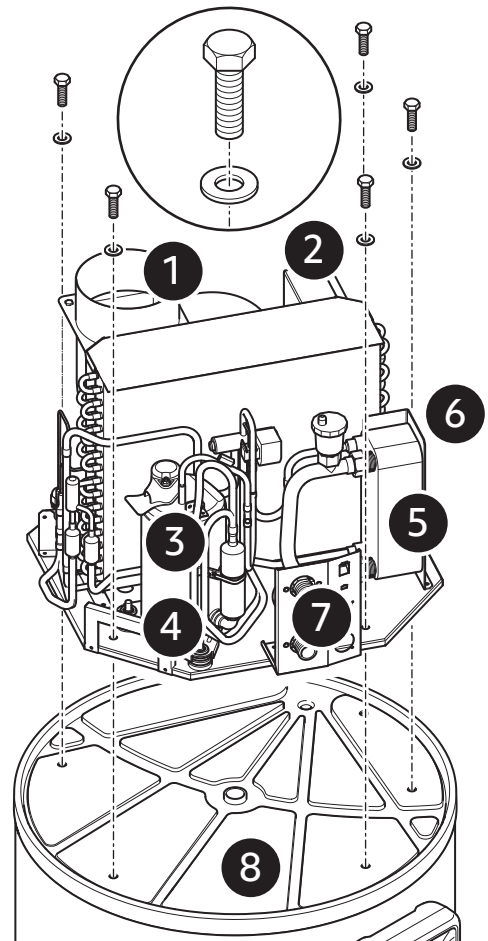

Fig. 11

10.0 Installation: Heat Pump Head Unit

10.3 Heat pump supply and immersion connections

Connect the heat pump supply and immersion cables to the heat pump connector panel.

The two PowerCON connectors should be inserted (1) then turned clockwise till they lock (2).

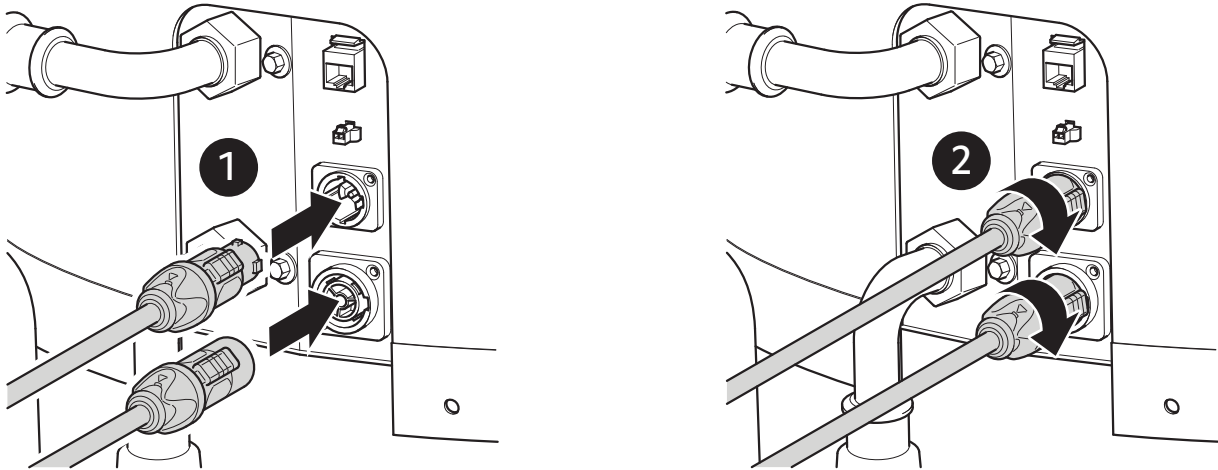

Fig. 12

10.4 Heat pump data connections

Connect the flow temperature **SENSOR** (two pin plug) and the **DATA** (RJ45) cables from the controller to the head unit connector panel (Fig. 13).

These two cables are normally supplied already connected to the controller. If not see 'Controller connector positions' on page 34 for the connector locations.

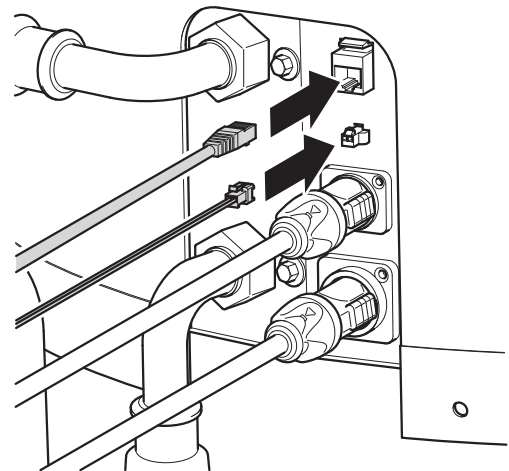

Fig. 13

11.0 Installation: Heat Pump Head Unit Pre Plumb Kit

11.1 Connect the Full Circulation Return Assembly

Connect the top port of the 3 way valve to the upper port of the head unit using the supplied 350mm flexi hose (3). Fit 3/4" fibre washers (supplied) when assembling the face seals.

11.2 Connect the Top Up Return Assembly

Fit 3/4" fibre washers (supplied) when assembling the face seals.

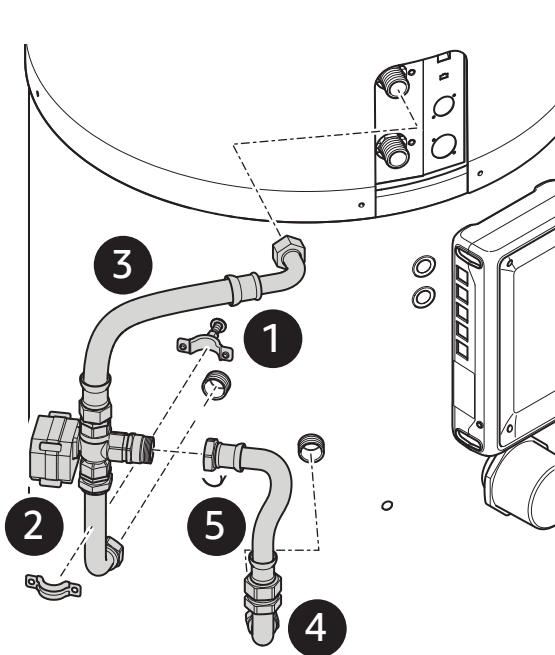

Fig. 14

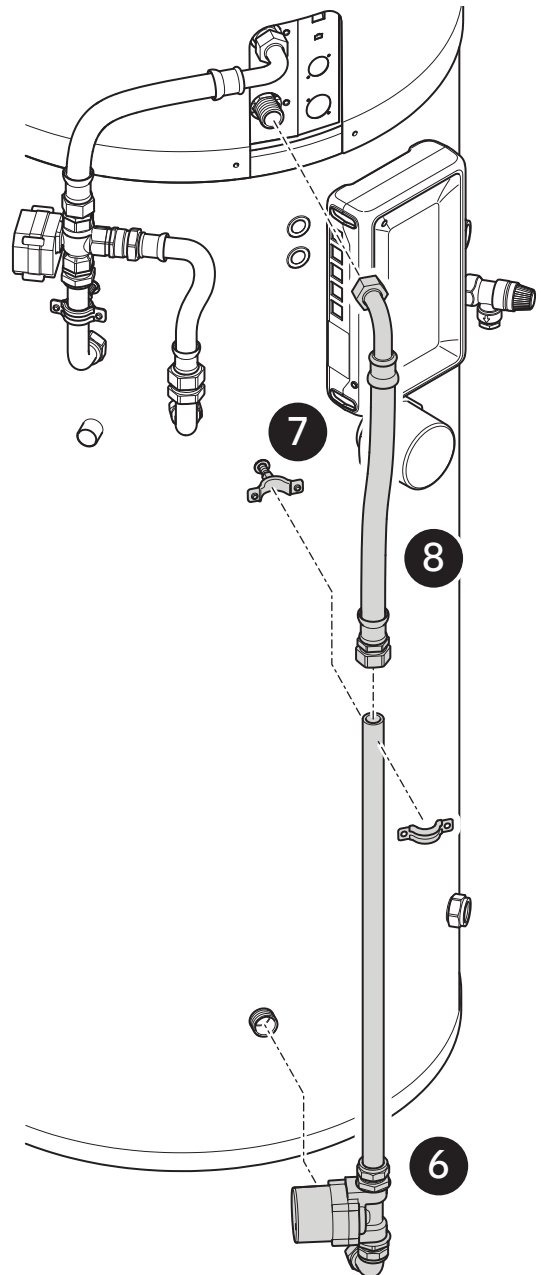

Fig. 15

1. Upper pipe clip location
2. Full Circ Return Assembly
3. Flexi hose 1 (350mm)
4. Top-Up Return Assembly
5. Flexi hose 2 (243mm)
6. Head Unit Feed Assembly
7. Lower pipe clip location
8. Flexi hose 3 (350mm 3/4" F x 22mm CM)

11.0 Installation: Heat Pump Head Unit Pre Plumb Kit

11.3 Fit Head Unit Feed Assembly

Connect the supplied flexi hose (8) to the lower port of the head unit then connect the other end to the 22mm pipe at the top of the head unit feed assembly using the integral compression gland.

Note that the face seal must be connected first to ensure proper alignment. Fit a 3/4" fibre washer (supplied) when assembling the face seal.

Do not attach the top cover until commissioning has taken place. Before use, the system will need bleeding and the bleed valve is inside the top cover. For more information, see 'Commissioning' on page 35.



It is the responsibility of the installer to ensure all compression and face seal fittings are tight and do not leak before leaving the property.

11.4 Valve Electrical Connection

Connect the valve actuator to the controller by connecting the actuator cable to the corresponding cable from the controller (Fig. 16). This cable is normally supplied already connected to the controller. If not see 'Controller connector positions' on page 34 for the connector location.

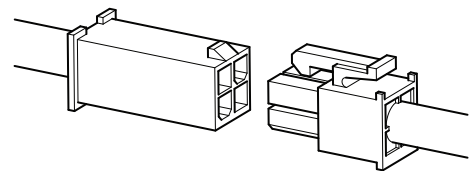

Fig. 16

11.5 Pre-plumb pipework insulation

The external pre-plumb pipework (Fig.17), should be insulated using class O insulation (not included).

The recommended thickness for class O insulation is 25mm for the best performance from your Mixergy iHP.

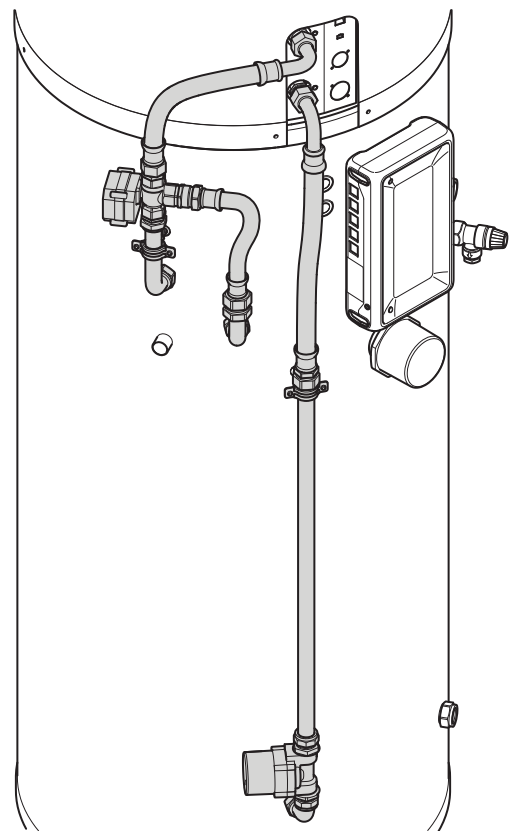

Fig. 17

12.0 Installation: Heat Pump Head Cover

12.1 Installing the top cover

The top cover should be fitted over the head unit with the side cut-out aligned with the connector panel. The top cover is secured with four self drilling screws (included). The screws do not require pilot holes.

The locations for the screws is indicated below by the red arrows.

Do not attach the top cover until the system has been bled. For more information, see 'Commissioning' on page 35.

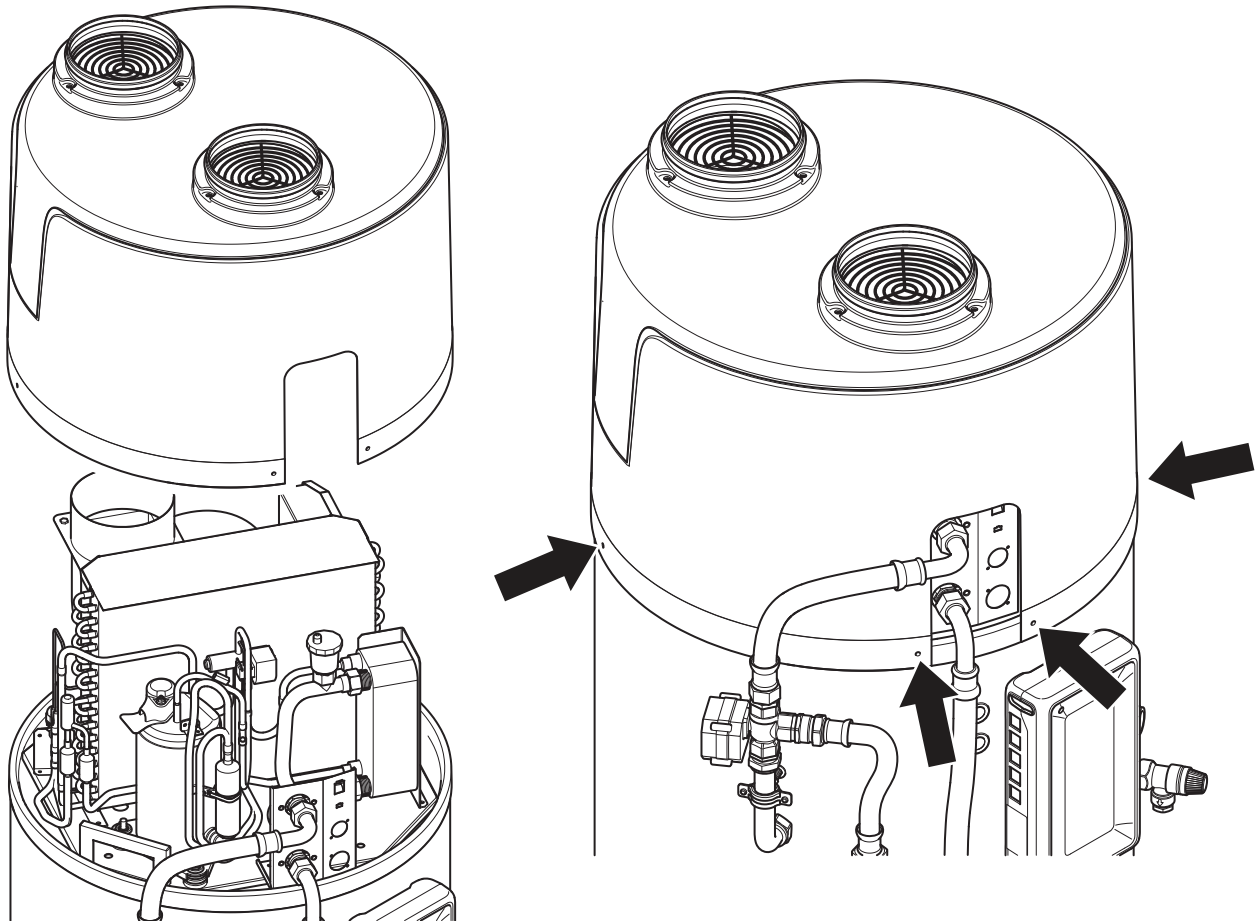

Fig. 18



Not installing the top cover mounting screws will result in air, and therefore heat, to be taken from the house. The screws help ensure the flow from the house is kept to a minimum.

12.2 Head Unit Sealing

To ensure minimal undesired exchange of air between the iHP and the installation location, the iHP has been fitted with a foam sealing kit. This sealing kit is designed to fill any gaps between the top cover, condensate tray and head unit.

When installing the head unit onto the condensate tray, there is a strip of foam already applied to the condensate tray. This foam strip will sit beneath the connector panel once the head unit is installed. The connector panel should compress the foam slightly, ensuring an air tight seal.

12.0 Installation: Heat Pump Head Cover



If the connector panel is not making proper contact with the foam strip, air from the installation location will be drawn into the head unit.

Inset from the bottom edge of the top cover, there is a foam strip that runs around the inside perimeter. There is also additional thickness of insulating foam around the mouse hole for the connector panel. When installing the top cover, the mouse hole should be aligned such that the surrounding foam is in contact with the sides and top of the connector panel.

The top cover can then be pushed downwards, and secured in place with the screws described on page 20.



Failure to apply downwards pressure whilst securing the top cover will result in an improper seal.

Whilst installing the top cover, attention should be paid to the seal between the fan and the top cover. The fan has a foam sealing ring on the outlet, and this sealing ring should make contact the full way around once the top cover is installed.

13.0 Installation: Heat Pump Ducting

13.1 Ducting Design

The iHP cylinder uses 150mm or 160mm i.d. ducting for the exhaust and intake of air to the heat pump head unit. Mixergy recommends the use of **Ubbink Aerfoam** for round duct iHP installations. If a mixture of round and flat ducting is required Mixergy recommends **Verplas Rapid Self-Seal Thermal** ducting.

- Minimise the number of bends in the ducting for best efficiency.
- A minimum of 300mm edge to edge between intake and exhaust ducting terminals should be observed, if there is no constraint on the facade of the building this dimension should be increased if practical to between 500mm and 1.5m.
- Vertical dusting through the roof directly above the head unit, will minimise bends. A 45 degree bend can be used to either route one duct to the opposite side of the roof or separate the external terminations.
- Ducting must be insulated to stop condensation forming on the exterior of the ducts.
- Avoid flexible ducting.
- Avoid high-loss louvres for side exits. If louvres are required ensure they are appropriately oversized to minimise losses. The use of bird-beak style side exits is recommended.
- If there are any air handling ports on an opposite wall 2m or closer (iHP, MVHR etc.), placement of the intake/exhaust ports should be no closer than 3.5m.

13.0 Installation: Heat Pump Ducting

- The recommended minimum distance from an opposite wall is 1m.
- The exhaust port should be no closer than 1m from any protruding wall or window or other opening. The same clearance should be given for open eaves.
- If installing for loft intake, ensure the intake is at least 500mm from any surface, especially any surface using Rockwool style insulation, as this will cause serious dust build up within the head unit.

When installing the ducting installation, it is important to allow for future servicing of the iHP head unit. As previously mentioned on page 8, 350mm should be left above the iHP to allow the top cover to be installed/removed. This 350mm of clearance also applies to the ducting.

The inlet and outlet ducting immediately above the iHP should be easy to detach and remove, giving the 350mm of clearance required for servicing.



If installing near a conventional boiler or property operating a conventional boiler, it is important to consider the impact of the iHP on the flues and subsequent air flow in the boiler. If the iHP intake/exhaust are too close to a boiler flue, it will affect the air flow to the boiler system which could lead to incomplete combustion. There is also a risk that the iHP intake will draw combustion products into the property.

The following should be considered:

- **For opposite walls under 2m away, the iHP intake/exhaust should be no closer than 3m to any boiler flue.**
- **The iHP intake/exhaust should be installed no closer than 2m from a protruding (perpendicular) wall containing a boiler flue.**
- **If installing on the same wall as a boiler flue, the intake/exhaust should be no closer than 2m to the flue. If there is an opposite wall less than 2m way, increase this distance to 3m.**
- **If the iHP intake/exhaust are exiting a wall, they should not be aimed directly at any vertical flues within 3m. If a vertical boiler flue is closer than 4m to the desired wall, the installer should aim to offset the iHP intake/exhaust by a minimum of 1m, while maintaining a minimum distance of 3m from the flue.**

These are guidelines only. It is the responsibility of the installer to ensure that the iHP installation has no effect on the operation any boiler system in close proximity to the iHP installation.

13.0 Installation: Heat Pump Ducting

Mixergy recommends the use of **Ubbink Aerfoam** for all iHP ducting installations. The design of this ducting means the losses created by typical PVC elbows are reduced by approximately 30%. This helps ensure the best performance from the iHP cylinder.

Below is a table of typical iHP ducting installations using generic PVC 150mm ducting and indicative COP figures to show the effect of different ducting designs. These COP figures are not a guarantee of performance, as there are many real world variables that will affect the achieved COP.

Duct length (m)	Instantaneous COP				
	Straight	2x Elbow, 90°	4x Elbow, 90°	2x Elbow, 90° + 2x Elbow, 45°	4x Elbow, 90° + 4x Elbow, 45°
1	3.33	2.84	2.55	2.75	2.40
5	3.27	2.79	2.51	2.71	2.36
10	3.19	2.74	2.47	2.66	2.31
15	3.10	2.69	2.42	2.61	2.26
20	3.00	2.64	2.36	2.57	2.22

Mixergy recommends a maximum duct length of 20 metres. All figures shown are for total combined duct length on the inlet and outlet of the iHP.

In the example shown to the right, if the length sum of S_1 , S_2 , S_3 and S_4 is 10 metres, and there are two 90° elbows, E_1 and E_2 , the resulting approximate COP would be 2.74.

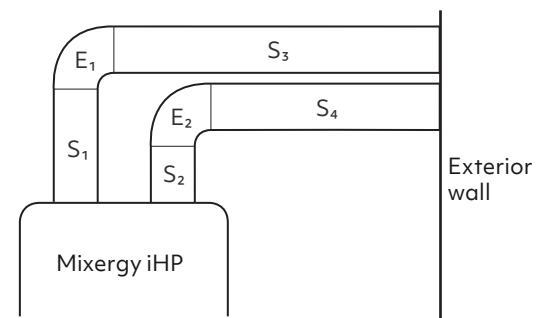

Fig. 19

Instantaneous COP was measured over a full reheat (full circulation mode) of the cylinder, from 10°C to 55°C, with 14°C inlet air.

If you need more in-depth information regarding fan and COP data for your installation, please contact Mixergy.

14.0 Building Regulation G3 Discharge Requirements

14.1 Discharge pipes from safety devices

As part of the requirements of Building Regulation G3 this product is factory fitted with a T&P valve, which complies with BS EN 1490. Any discharge from a water heater system should be conveyed to where it is visible but will not cause danger to persons in or about the building. The tundish and the discharge pipes should be fitted in accordance with the requirements of Building Regulation approved document G3, (England and Wales), Part P of Northern Ireland and Standard 4.9 of Scotland.

14.2 Tundish

- The tundish should be vertical, located in the same space as the unvented hot water storage system and be fitted as close as possible to, and lower than, the safety device, with no more than 600mm of pipe between the valve outlet and the tundish. Note: to comply with the Water Supply (Water Fittings) Regulations, the tundish should incorporate a suitable air gap.
- Any discharge should be visible at the tundish. In addition, where discharges from safety devices may not be apparent, e.g. in dwellings occupied by people with impaired vision or mobility, consideration should be given to the installation of a suitable safety device to warn when discharge takes place, e.g. electronically operated.

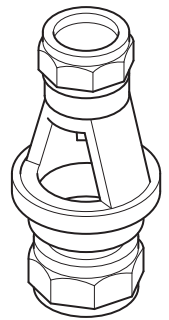

Fig. 20

14.3 Discharge Pipe D2

The discharge pipe (D2) from the tundish should have a vertical section of pipe at least 300mm long below the tundish before any elbows or bends in the pipework. It should be installed with a continuous fall of at least 1 in 200.

The discharge pipe (D2) should be made of metal or other material that has been demonstrated to be capable of safely withstanding temperatures of the water discharged and is clearly and permanently marked to identify the product and performance standard (e.g. as specified in the relevant part of BS 7291-1:2006).

Mixergy strongly recommends the use of metal pipework only and Mixergy does not take responsibility for any damage caused from discharges.

The discharge pipe (D2) should be at least one pipe size larger than the nominal outlet size of the safety device unless its total equivalent hydraulic resistance exceeds that of a straight pipe 9m long, i.e. for discharge pipes between 9m and 18m the equivalent resistance length should be at least two sizes larger than the nominal outlet size of the safety device; between 18 and 27m at least 3 sizes larger, and so on; bends must be taken into account in calculating the flow resistance.

15.0 Discharge pipework

15.1 Typical discharge pipe arrangement

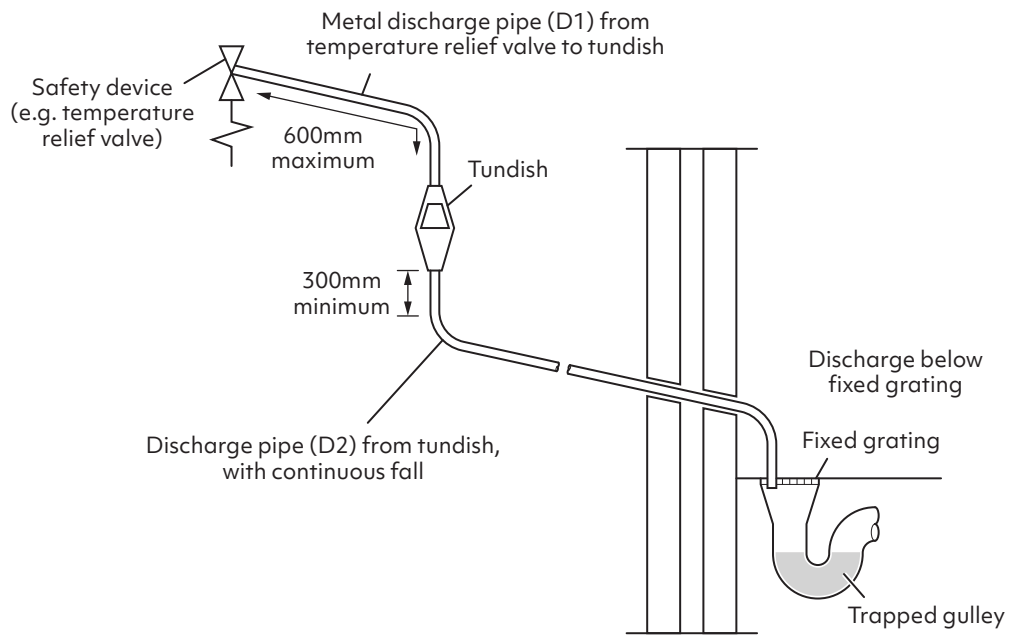

Fig. 21

15.2 Sizing of copper discharge pipe D2 for common temperature relief valve outlet sizes

Valve outlet size	Minimum size of discharge pipe D1	Minimum size of discharge pipe D2 from tundish	Maximum resistance allowed, expressed as a length of straight pipe	Resistance created by each elbow or bend
G 1/2"	15mm	22mm	< 9m	0.8m
		28mm	<18m	1.0m
		35mm	<27m	1.4m
G 3/4"	22mm	28mm	<9m	1.0m
		35mm	<18m	1.4m
		42mm	<27m	1.7m
G 1"	28mm	35mm	<9m	1.4m
		42mm	<18m	1.7m
		54mm	<27m	2.3m

15.0 Discharge pipework

15.3 Discharge pipe D2

- The discharge pipe (D2) from the tundish should have a vertical section of pipe at least 300mm long below the tundish before any elbows or bends in the pipework. It should be installed with a continuous fall of at least 1 in 200.
- The discharge pipe (D2) should be made of metal or other material that has been demonstrated to be capable of safely withstanding temperatures of the water discharged and is clearly and permanently marked to identify the product and performance standard (e.g. as specified in the relevant part of BS 7291-1:2006.)
- The discharge pipe (D2) should be at least one pipe size larger than the nominal outlet size of the safety device unless its total equivalent hydraulic resistance exceeds that of a straight pipe 9m long, i.e. for discharge pipes between 9m and 18m the equivalent resistance length should be at least two sizes larger than the nominal outlet size of the safety device; between 18 and 27m at least 3 sizes larger, and so on; bends must be taken into account in calculating the flow resistance.
- Where a single common discharge pipe serves more than one system, it should be at least one pipe size larger than the largest individual discharge pipe (D2) to be connected.

An alternative approach for sizing discharge pipes would be to follow Annex D, section D.2 of BS 6700:2006 + A1:2009 Specification for design, installation, testing and maintenance of services supplying water for domestic use within buildings and their curtilages.

- The discharge pipe should not be connected to a soil discharge stack unless it can be demonstrated that the soil discharge stack is capable of safely withstanding the temperatures of the water discharged, in which case, it should contain a mechanical seal, not incorporating a water trap, which allows water into the branch pipe without allowing foul air from the drain to be ventilated through the tundish.
- If plastic pipes are used as branch pipes carrying discharge from a safety device, they should be either polybutylene (PB) or cross-linked polyethylene (PE-X) complying with national standards such as Class S of BS 7291-2:2006 or Class S of BS 7291-3:2000 respectively; and be continuously marked with a warning that no sanitary appliances should be connected to the pipe.
- Where pipes cannot be connected to the stack it may be possible to route a dedicated pipe alongside or in close proximity to the discharge stack.

Plastic pipes should be joined and assembled with fittings appropriate to the circumstances in which they are used as set out in BS EN ISO 1043-1:2002.

15.0 Discharge pipework

15.4 Termination of discharge pipe

The discharge pipe (D2) from the tundish should terminate in a safe place where there is no risk to persons in the vicinity of the discharge.

Examples of acceptable discharge arrangements are:

- To a trapped gully with the end of the pipe below a fixed grating and above the water seal.
- Downward discharges at low level; i.e. up to 100mm above external surfaces such as car parks, hard standings, grassed areas etc. are acceptable providing that a wire cage or similar guard is positioned to prevent contact, whilst maintaining visibility.
- Discharges at high level: e.g. into a metal hopper and metal downpipe with the end of the discharge pipe clearly visible or onto a roof capable of withstanding high temperature discharges of water and 3m from any plastic guttering system that would collect such discharges.

15.5 Termination of condensate hose

- The condensate drain is located to the right of the controller on the side of the cylinder. Approximately 2m of 20mm id flexible hosing is provided. This should be connected to a grey water drainpipe, D2 of the tundish pipe work or to a soil pipe.
- The head unit will discharge approximately 0.75L of water per hour under typical operating conditions.
- The hose should not run horizontally or create a U-bend.
- If discharging into a drain or soil pipe a U-bend should be used. The outlet of the U-bend **MUST** be below the inlet to avoid water backing up into the head unit.
- If discharging into D2 of the tundish pipe work, a swept tee should be used to prevent discharge traveling up the condensate drain hose and check that the outlet is suitable for continuous discharge.

16.0 Fitting the gauge

The gauge has a magnetic backing strip to attach directly to the cylinder, or by using the self adhesive pad can be installed outside of the cylinder cupboard for easy user access.

If required, the cable can be extended by using a RJ11 extension cable (available from Mixergy).

Insert the connector into the control box (Fig. 15).

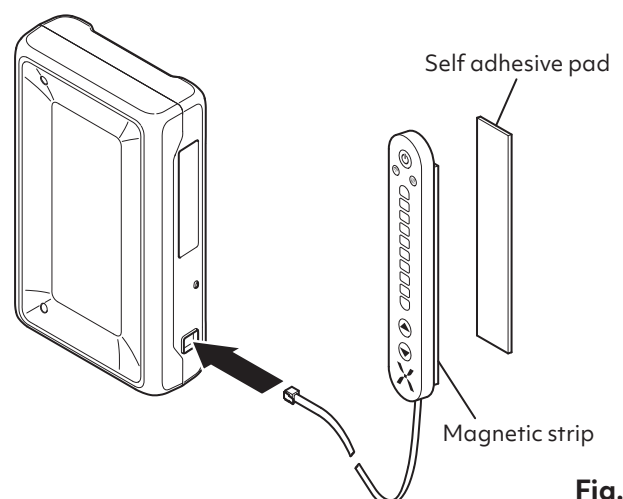

Fig. 22

17.0 Installation: electrical

17.1 Indirect units and electrical wiring

On indirect units, where a coil is fitted to the cylinder, the supplied two port motorized zone valve must be fitted when the indirect source is capable of exceeding 70°C in accordance with the instruction details supplied for the appropriate installation. Maximum working pressure of the coils is 3.5 Bar. All electrical wiring to electronics, zone valve and immersion heaters must be earthed and to current IEE Wiring Regulations.



ENSURE ALL ELECTRICAL SUPPLIES ARE SWITCHED OFF BEFORE MAKING ANY CONNECTION TO THE UNIT.

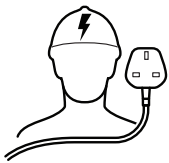

ELECTRICAL INSTALLATION MUST BE CARRIED OUT BY COMPETENT ELECTRICIAN AND BE IN ACCORDANCE WITH THE LATEST I.E.T. REGULATIONS

17.2 External wiring

Mixergy cylinders come supplied with cable. Any extensions to the supplied cabling should match or exceed the current and voltage ratings of the cables to be extended.

17.3 Primary supply (13A, 230-240V~, 1.5mm² CSA)

The white 3-core (L,N,E) cable labelled '**PRIMARY SUPPLY**' must be connected to the household's main supply via a dedicated 16A MCB protected circuit with a 20A DP switch. This is the primary power supply for the control electronics and is used to power the immersion when the cylinder is set to heat in direct mode.

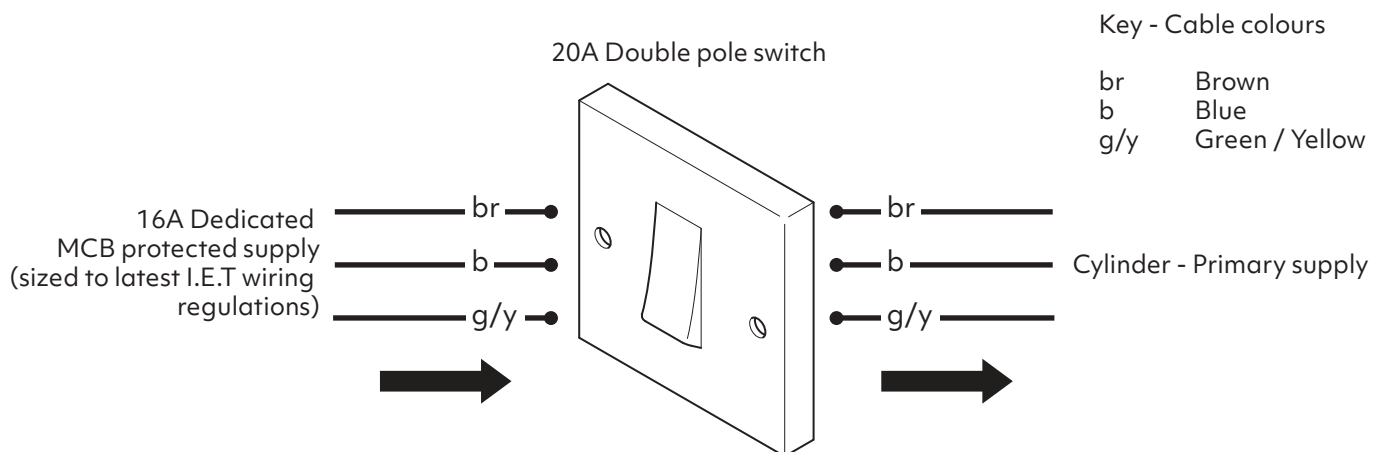

Fig. 23

17.0 Installation: electrical

17.4 Timer control (VOLT-FREE, 10mA 80-240V~, 0.5mm² CSA)

The black 3-core (L,N,E) cable labelled 'TIMER CONTROL' can be used to integrate the Mixergy cylinder with any existing timers or controllers i.e. economy 7 timer or a hive dual channel controller. This cable detects a 80-240VAC signal and instructs the cylinder to heat unless otherwise disabled in software.

The timer control cable is attached to volt free contacts within the controller and can be safely left unterminated if not required.



Please note - All figures shown in this manual are for the R290 version of the Mixergy iHP.

17.5 Wiring diagram

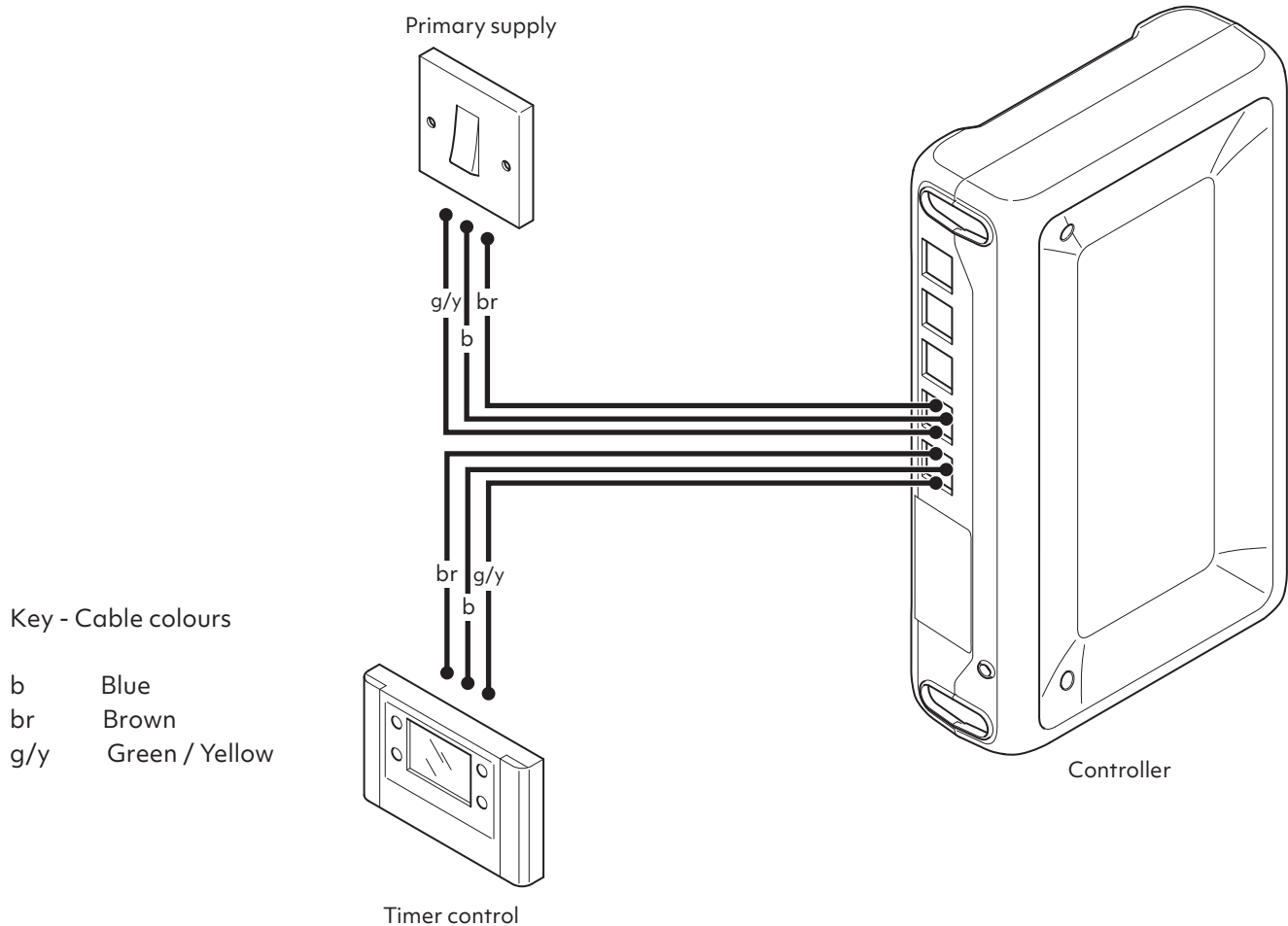

Fig. 24

18.0 Installation: connectivity

18.1 Installing the powerline adaptor

The Mixergy cylinder requires internet connectivity to allow for full control of the system. Connection to the cylinder can be made using the provided ethernet to powerline adaptor or by hard-wired ethernet.

If an existing HomePlug AV powerline network is installed at the property, it is recommended to pair the cylinder with the existing network as per page 24. Powerline connectivity between the cylinder and internet router is only possible in houses where both the cylinder and adaptor are powered from the same electrical phase.



DO NOT USE AN EXTENSION LEAD AS THIS WILL NOT ALLOW THE POWERLINE TO WORK CORRECTLY

1. Plug the powerline adaptor into a wall socket within 2m of the internet router.
2. Plug the powerline adaptor into the internet router using the included 2m ethernet cable.

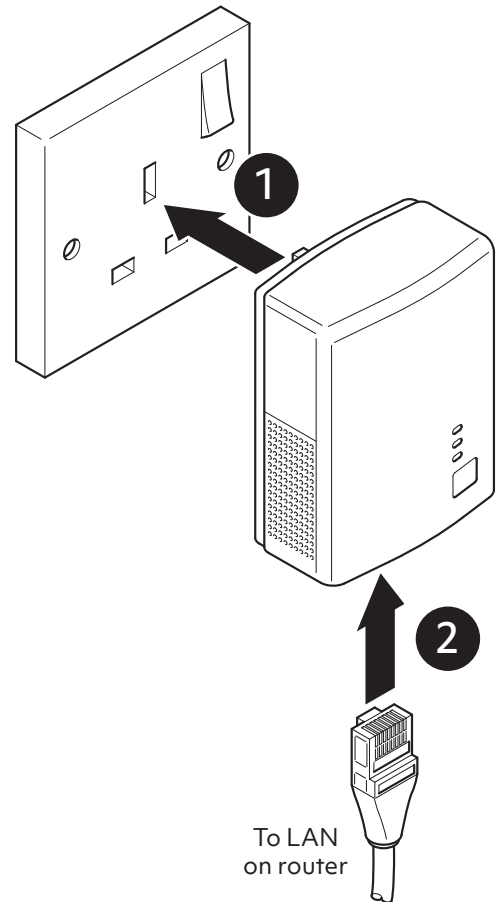

Fig. 25

18.0 Installation: connectivity

18.2 Wiring an ethernet connection

If a hard-wired CAT5/CAT5e/CAT6 network connection is desired, this can be achieved as follows:

ENSURE ALL ELECTRICAL SUPPLIES ARE SWITCHED OFF BEFORE OPENING THE CYLINDER CONTROLLER COVER AND SAFE ISOLATION PROCEDURE IS FOLLOWED (see page 31).

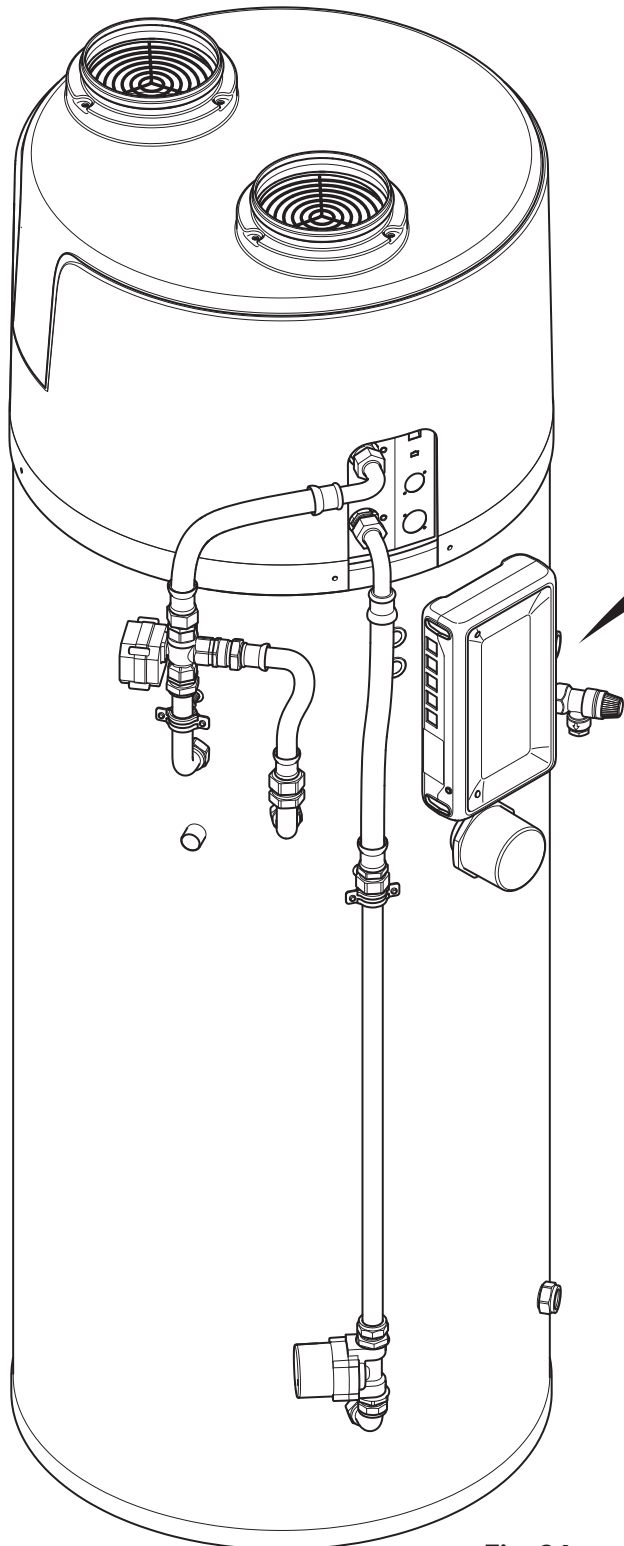

Fig. 26

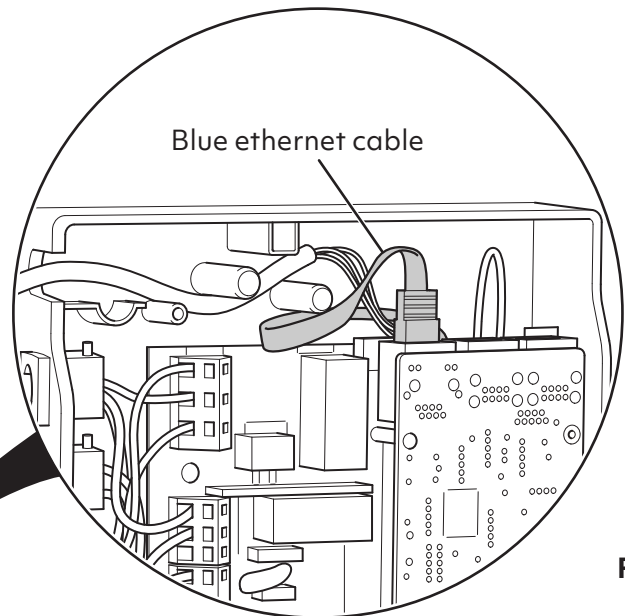

Fig. 27

1. Unscrew and remove the cylinder controller's cover and then disconnect the blue ethernet cable (Fig. 27).

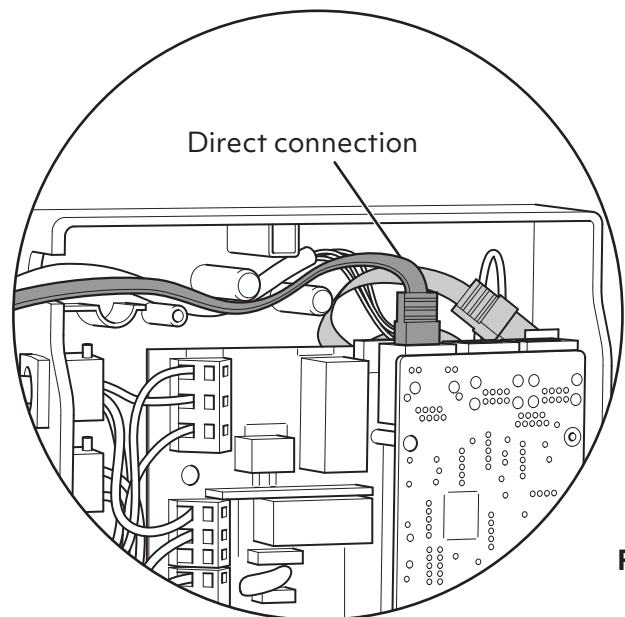

Fig. 28

2. Replace the removed ethernet cable with a suitable direct connection to the network (broadband router/switch) (Fig. 28).

19.0 Current reader kit installation (option)

19.1 Overview

If the property has solar PV panels there is an option to fit a current reader on the mains supply to the property. This measures energy import and export. If the energy export exceeds a threshold (typically 250-500W) the controller will switch on the heat pump to use the excess energy to heat water.

A standard Cat5e or Cat6 cable is used to connect the controller to the current reader and there is also a wireless option.

There are two options depending on the type of supply the property has:

The **MAS0071** kit is intended for properties with a single-phase supply.

If it is impractical to install a cable between the controller and the mains supply then a wireless unit is available.

The part number for this is **MAS0182-WL**. The installation instructions for this unit are supplied as part of the kit.

19.2 Included parts - MAS0071 single current clamp kit

- Current clamp interface MK2 (MAS0196) x1
- SCT-16 current clamp (MEC0029) x1
- Mounting hardware (VHB pad, screws x2, wall plugs x2)
- 1m ethernet cable x1, 2m ethernet cable x1

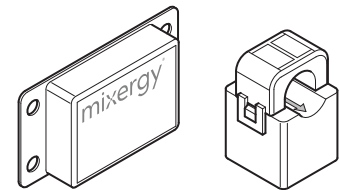

Fig. 29

19.3 Positioning the CT interface

The current clamp interface must be placed within 300mm of the household's incoming mains supply cabling and should be fixed to the wall with the provided screws or adhesive pad.

19.0 Current reader kit installation (option)

19.4 Installation of the current clamp

The current clamp should be attached around the neutral (blue or black) cable on the incoming mains supply with the arrow pointing towards the incoming supply 80/100A main fuse or breaker.

If this is impractical it can be fitted round the live (brown or red) cable with the arrow pointing away from the incoming supply.

The current clamp must then be plugged into the current clamp interface (Fig. 31).

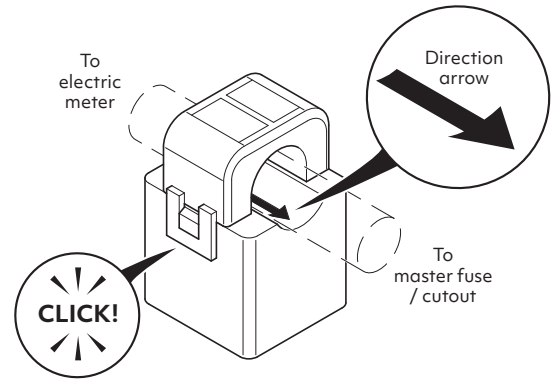

Fig. 30

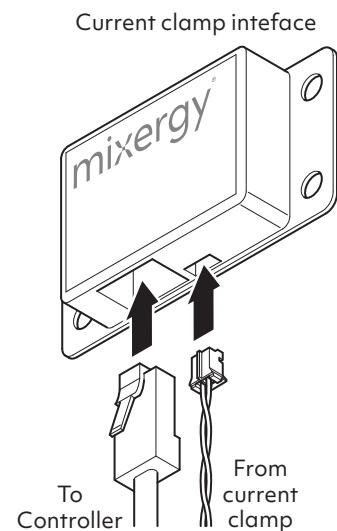

Fig. 31

19.5 Connection of the CT interface to the controller

The CT interface should be connected to the controller using pin to pin cat5e or cat6 Ethernet cables.

Ensure that the cable used contains all 4 twisted pairs (8 conductors).

NOTE: While Ethernet cable is used for this connection, the communication protocols used are not compatible with standard networking hardware and the connection between the controller and clamp must be direct (i.e. no network switches or routing equipment is to be fitted in between).

Remove the controller lid and connect one end of the cable to J55 at the lower left corner of the controller circuit board or to the zoneBus Out connector on the mezzanine board (Fig. 32). The other connector is used to control the heat pump and should already be connected.

Connect the other end to the RJ45 connector on the single CT interface (Fig. 31).

19.0 Current reader kit installation (option)

19.6 Controller connector positions

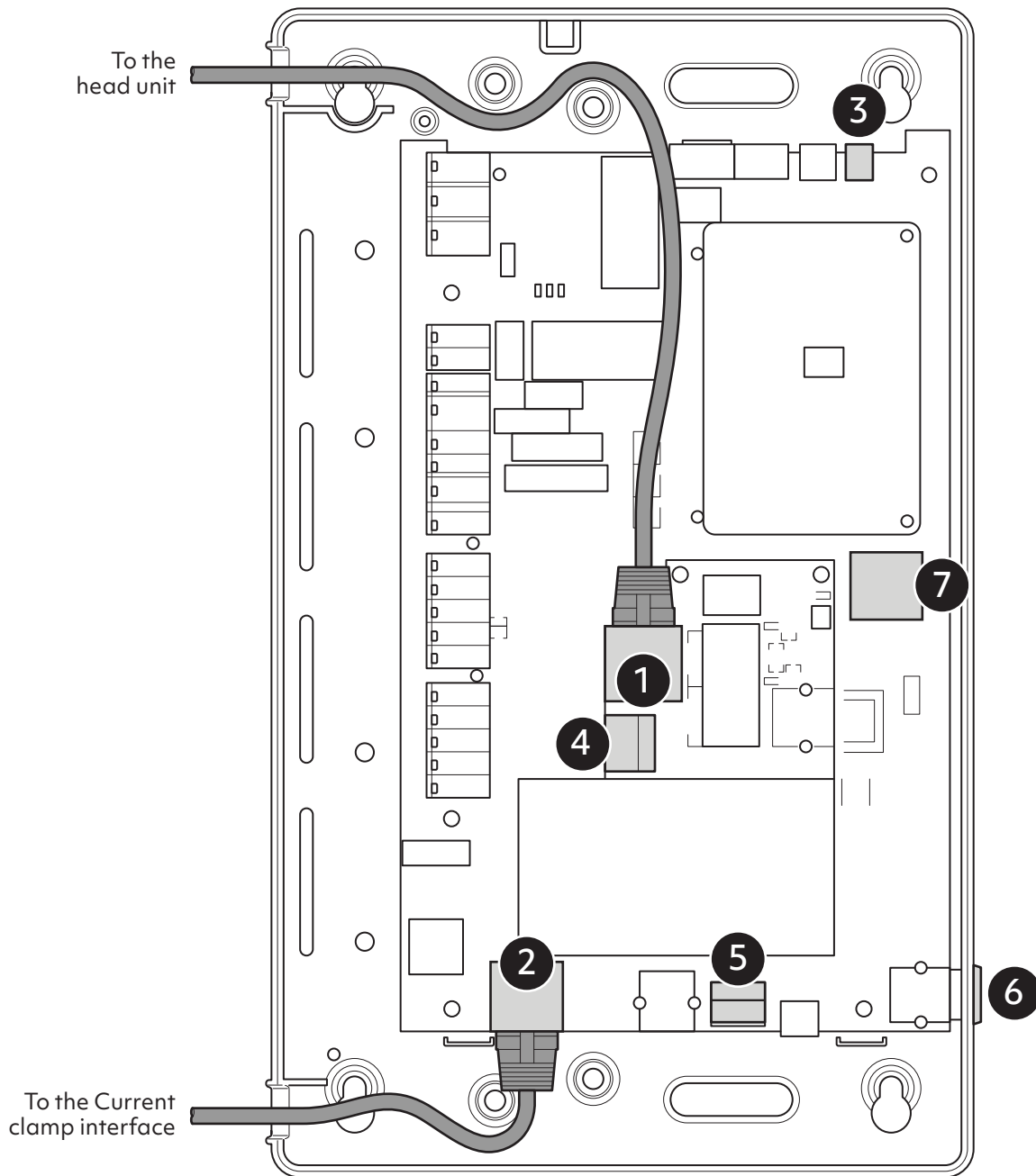

Fig. 32

1. Data connection - zoneBus Out
2. Data connection - J55
3. Heat pump sensor connector - J5
4. Valve connection
5. Tank pump connector - J6
6. Gauge connector
7. Tank sensor connector - J44

20.0 Commissioning

20.1 Fill and bleed the system

1. Ensure the drain on the cold feed pipework is closed.
2. Before turning on the mains supply to the cylinder a hot water tap should be opened, preferably on the same floor or the floor below where the cylinder is located.
3. Check the pre-charge in the expansion vessel and ensure it is at least 3 bar. Note actual pressure on label on expansion vessel.
4. Turn on the supply and fill until water appears at the hot tap. Continue to flush the system until all debris has been removed.
5. Close the hot water tap.
6. Check all joints for leaks, even those not having been altered especially when replacing a vented water heater.
7. Ensure water flow is obtained at each hot water outlet expelling any air within the pipework. Once finished, close all hot water outlets.
8. Locate the auto air vent on the head unit (Fig. 33) and loosen the cap.

Air will be released from the top of the system.

The cap can be left loose on the air vent. Do not remove the cap.

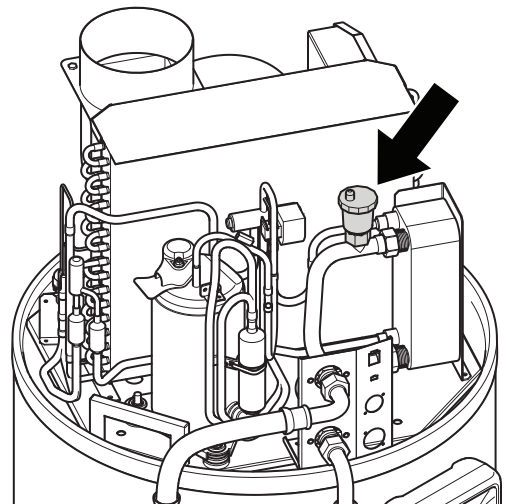

Fig. 33

9. Open temperature and pressure relief valve to ensure proper discharge and check after closing that valve is not dripping.
10. Open expansion relief valve to ensure proper discharge and check after closing that valve is not dripping.
11. Check that the discharge pipework is free from debris and is transporting the water away to waste effectively.

20.0 Commissioning



DO NOT SWITCH THE SYSTEM ON UNLESS THE CYLINDER IS COMPLETELY FILLED WITH WATER.

12. Switch on the supply to the Mixergy iHP cylinder and check for correct operation.

On power up the tank controller runs a series of tests and displays the results on the gauge.

Note that this will only run when the main controller has booted up which takes approximately 50 seconds.

Check that no LEDs light red and that the bottom seven LEDs light green.

The picture to the left shows the meaning of each LED.

Note that if a voltage is applied to the Remote Control input the Remote Control LED will light green rather than blue.

Check that all buttons (boost UP, boost DOWN and power) work correctly.

For further information on gauge operation please reference the Mixergy iHP User Guide.

13. Connect the cylinder to the internet by pairing to the included powerline adapter. See page 29 and page 39 for more information. The Network LED will light when the system is connected to the Mixergy server.

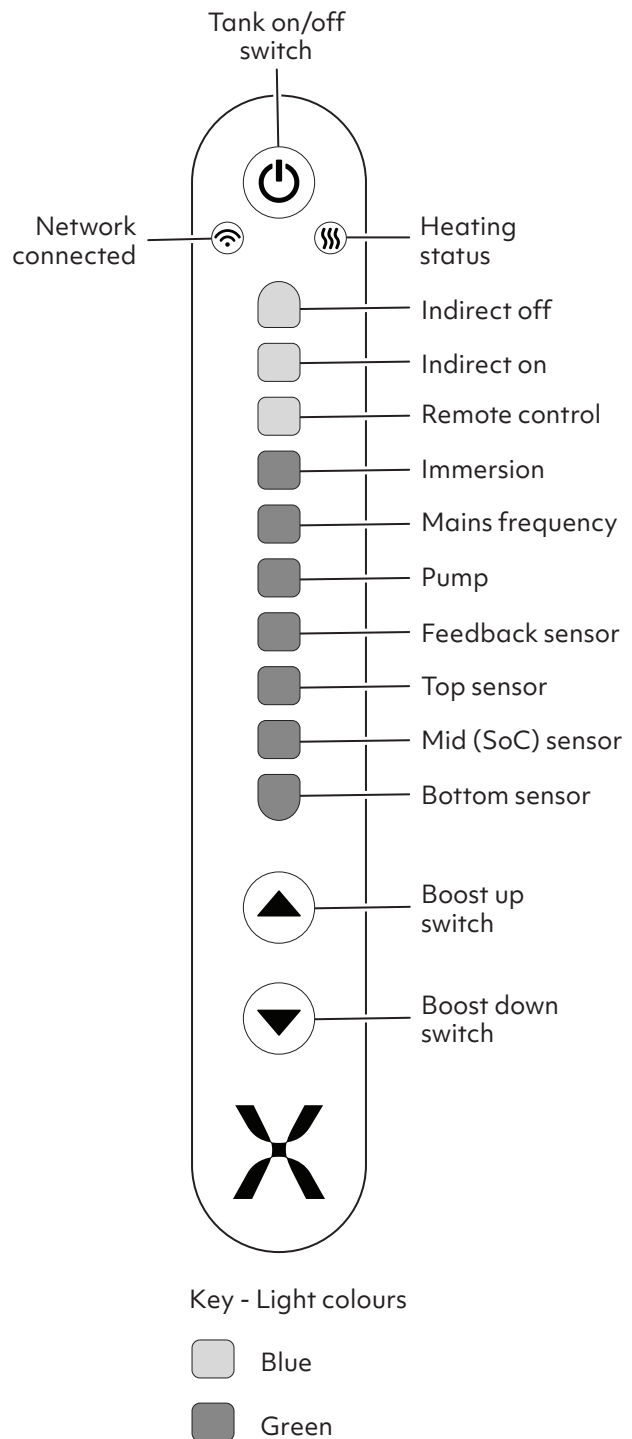

Fig. 34

20.0 Commissioning

20.2 Changing heating mode

All Mixergy systems leave the factory in full circulation mode. If you wish to permanently enable top-up mode, this can be achieved in a number of ways:

1. If the system is connected to the internet the heating mode can be changed by the installer using the Mixergy Enterprise Installer app or by the user via the standard Mixergy app.
2. Alternatively the heating mode can be set by holding the boost UP and boost DOWN buttons simultaneously. The display will light white to acknowledge that you have entered this mode. To change the heat source, let go of the buttons once any of the display LEDs has changed to the required colour (BLUE for Full Circulation, RED for top-up). The display will then flash either blue or red to indicate the new default heat source. Switch the cylinder off and on (power cycle) for the change to take effect.

Please note that any heat source that is set while the cylinder is offline will be overwritten once the cylinder establishes an internet connection, please ensure that the default heat source is set correctly on the app once the system is fully connected.

20.3 Status LED error codes

If the system is not behaving as expected, please check the status LED on the side of the controller enclosure and contact Mixergy:

- **Flashing green:** System OK.
- **Solid green/red:** System updating (DO NOT REMOVE POWER).
- **Very slow flashing red (once every two seconds):** Temp. sensor problem.
- **Slow flashing red (once a second):** No gauge detected.
- **Fast flashing red (twice a second):** Energy measurement issue.
- **Very fast flashing red (five times a second):** Main processor issue.

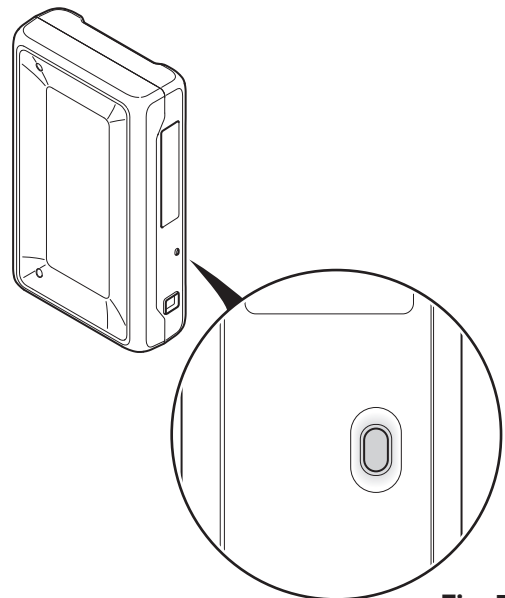

Fig. 35

20.0 Commissioning

20.4 Pairing the cylinder and connecting to the internet

In the case that the cylinder does not automatically pair to the powerline adaptor or connection to an existing homeplug AV network is desired, please follow the steps below to pair the cylinder to the network.

1. Use a thin tool to depress and hold the pair button for 1 - 2 seconds.
2. Depress the pair button on the powerline adaptor for 1-2 seconds within 2 minutes of step 1.
3. Observe all 3 LEDs as solid green on the powerline adaptor.

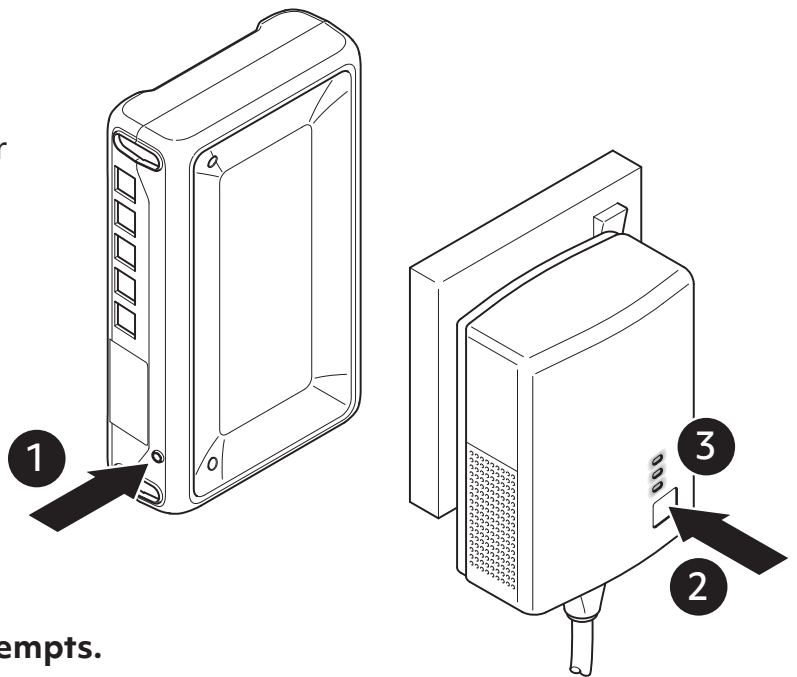

Fig. 36

NOTE: Steps 1-3 could take multiple attempts.

The cylinder must be registered and connected online in order to validate the manufacturer's 25 yr warranty.

20.0 Commissioning

20.5 Commissioning checklist

This Commissioning Checklist is to be completed in full (either in this booklet or on the side of the cylinder) by the competent person who commissioned the cylinder as a means of demonstrating compliance with the appropriate Building Regulations.

Failure to install and commission this equipment to the manufacturer's instructions may invalidate the warranty but does not affect statutory rights.

Please ensure all information is filled in correctly below.

Customer name:		Telephone No:	
Address:			
Cylinder make & model:			
Cylinder serial no:			
Commissioned by: (Print name)		G3 Certificate No:	
Company name:		Telephone No:	
Company address:			

ALL SYSTEMS

What is the incoming static cold-water pressure at the inlet to the system?				bar
Has the strainer been cleaned of installation debris?	Yes		No	
Is the installation in a hard water area (above 200ppm)?	Yes		No	
If yes, has a scale reducer been fitted?	Yes		No	
What type of scale reducer has been fitted?				
What is the hot water temperature set to?				°C
What is the maximum hot water flow rate (measured at high flow outlet)?				min
Time & temperature controls have been fitted in compliance with Part L of the Building Regulations?	Yes			
Is the cylinder renewable compatible?	Yes		No	
What is the hot water temperature at the nearest outlet?				°C
All appropriate pipes have been lagged up to 1m or at the point they become concealed?	Yes			

20.0 Commissioning

UNVENTED SYSTEMS ONLY

Where is the pressure reducing valve located?				
What is the pressure reducing valve setting?	Bar			
Has a combined temperature & pressure relief valve and expansion valve been fitted, and discharge tested?	Yes		No	
The tundish & discharge pipework have been connected and terminated to Part G Building Regulations?	Yes		No	
Are all energy sources fitted with a cut-out device?	Yes		No	
Has the expansion vessel been checked?	Yes		No	

ALL INSTALLATIONS

The hot water system complies with the appropriate Building Regulations	Yes	
The system has been installed in accordance with the manufacturer's instructions	Yes	
The system has been commissioned in accordance with the manufacturer's instructions	Yes	
The system controls have been demonstrated to and understood by the customer	Yes	
The cylinder has been connected to the internet and the customer has been registered online	Yes	
The manufacturer's literature has been explained and left with the customer	Yes	
Building Regulations Notification Number (if applicable)		
To be completed by the customer on receipt of a Building Compliance Certificate*		
Commissioning Engineer's Signature		
Customer's signature (to confirm satisfactory demonstration & receipt of manufacturer's literature)		

*All installations in England and Wales must be notified to Local Authority Building Control (LABC) either directly or through a Competent Persons Scheme. A Building Regulation Compliance Certificate will then be issued to the customer.

21.0 Problem solving



Discharge from either of the relief valves indicates a malfunction in the system and must be investigated immediately.

21.1 Overheated water

In the unlikely event of overheated (95°C) water being discharged, the Mixergy controller should be switched off immediately and a competent engineer called out. Please contact your original installer or contact Mixergy directly if your product is under warranty.



Do not shut off the cold water supply to the unit.

21.2 Water discharge

If water is occasionally being discharged during heating, this likely indicates that the Expansion Vessel needs to be recharged. In the event of this occurring, switch off all power supplies to the cylinder, and re-charge the vessel. If water is continually being discharged, firstly check with a gauge that the pressure allowed through the PRV does not exceed 3 bar. Should a replacement be required then only one supplied by Mixergy should be used.

21.3 Electrical fault

If an electrical fault of the controller is suspected or the electrical system does not operate as expected, please visit support.mixergy.co.uk for further guidance.

21.4 Connectivity issues

If a connectivity issue is suspected, please visit support.mixergy.co.uk for further guidance.

21.5 Expansion vessel check and re-charging

Check pressure via the Schrader valve on top of the vessel which is situated under the removable plastic cap. The vessel can be checked and recharged by switching off the stopcock or isolating the water supply to the cylinder, then opening a hot tap to deplete the pressure inside the cylinder. Unscrew the black plastic cap on the expansion vessel to reveal the Schrader valve, with the aid of a pressure gauge ensure the pressure reads 3.0 bar. If there is insufficient pressure within the vessel, top up the vessel via a pump and recharge to 3.0 bar.

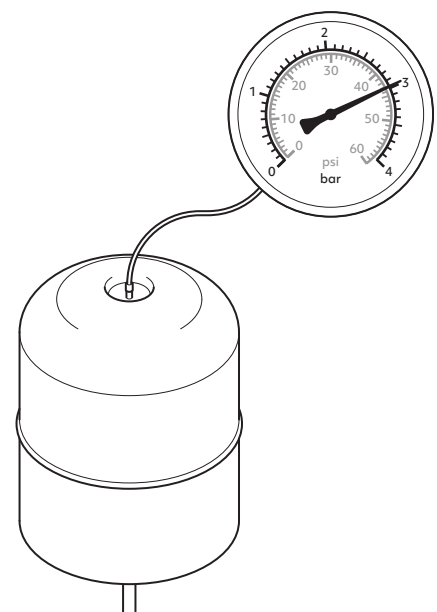

Fig. 37

21.0 Problem solving

21.6 Safety valves

If all previous checks have been done and water is still being discharged from either safety valve, determined which valve is faulty and replace with one supplied by Mixergy.

21.7 Immersion heaters

If the immersion heater is not heating the water adequately it has either failed (in which case a replacement immersion heater as supplied by Mixergy should be fitted), an electrical fault is present or the electrical cut-out has operated due to the control thermostat being set too low or being faulty. Activate the reset button under the immersion cover. If the problem persists please visit support.mixergy.co.uk

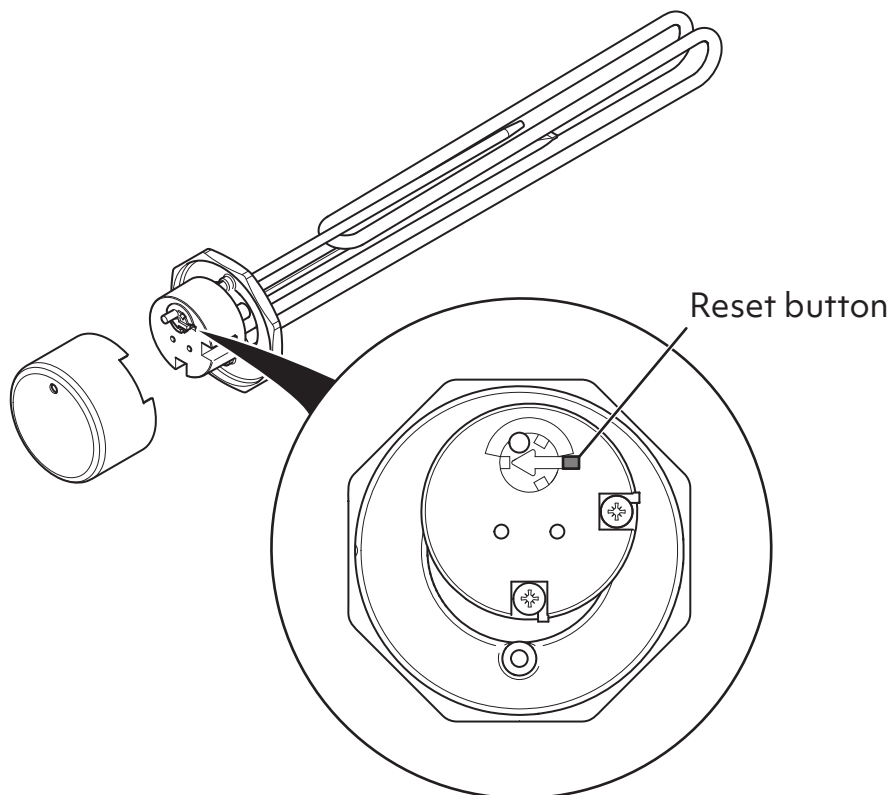

Fig. 38

22.0 Draining the cylinder

1. Switch off the immersion heater(s), boiler and any other heat sources.
2. Switch off water at mains.
3. Open nearest hot tap.
4. Open drain to start draining the cylinder.

To re-fill follow the commissioning instructions.

22.1 Flushing the cylinder

To flush out the system, drain the unit as above, fill and repeat.

If after recharging the expansion vessel the cylinder is still discharging, it may be due to cross-flow - ensure appropriate check valves are fitted. The pressure reducing valve, one of the relief valves, or the expansion vessel may have failed. The component should be identified and replaced by one supplied by Mixergy.

23.0 Replacement parts

Do not attempt to repair or replace any parts of the Mixergy cylinder unless you are a trained operative. If you suspect a fault or a replacement part is needed, please visit: support.mixergy.co.uk

To determine the correct parts for your system, please ensure you have your cylinder MX number which can be found on the nameplate located at the front of the cylinder.

Model code	MX-180-ELE-EXT-550-1-1-A
Total weight	227 kg (wet), 54 kg (dry)
Immersion heater rating	230-240 V~ 2.7-3.0 kW
Immersion heater type	1 3/4" BSP – 400mm Incoloy
Standing heat loss/24 hr	1.8 kWh
Heat exchanger rating	-- kW
Max. supply pressure	1 MPa (10 bar)
Expansion relief pressure	0.6 MPa (6 bar)
Max. operating pressure	0.55 MPa (5.5 bar)
Max. coil pressure	0.35 MPa (3.3 bar)



MX000000 

Scan the QR code to add your tank to your account or visit www.mixergy.io/register

mixdevice-aaaaa-bbbbb-cccc-ddddd-eeee

Fig. 39

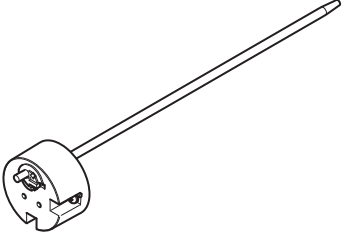
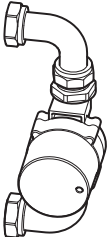
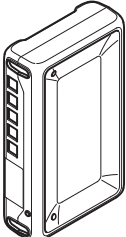
23.0 Replacement parts

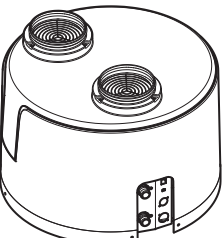
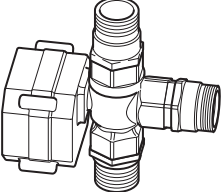
Part description	Part number
Immersion stat 	MEL0018
Pump assembly 	MAS0092/93/94
Controller 	MAS0005
Gauge 	MAS0043
Head unit 	MEL0082
3-way ball valve 	MEL0023

24.0 Guide to safe isolation

A Mixergy cylinder may have more than one incoming main electrical supply.

Indirect control black wire on connection 2.

Primary supply brown wire on connection 6.

Timer control brown wire on connection 8.

All of which must be "Proven Dead" before commencing work.

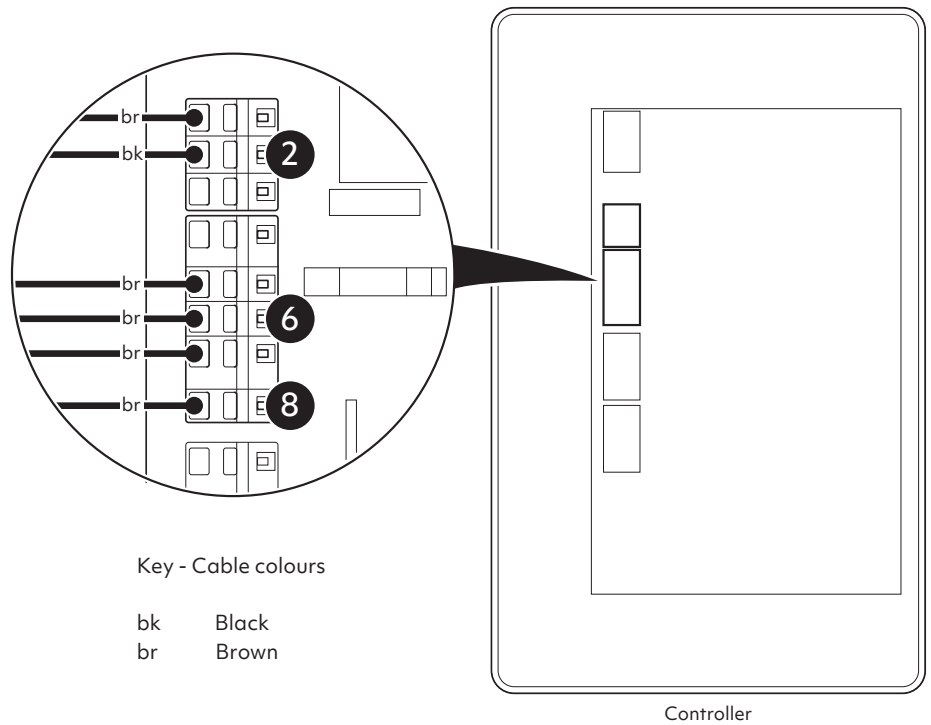

Fig. 40

A Mixergy cylinder may have more than one point of isolation:

Primary supply: 16A MCB protected circuit with a 20A DP switch

Indirect control: 3A fuse spur

Timer control: 3A or 13A fuse spur

All of which must be isolated and locked-off before testing.

For more information on safe isolation see www.electricalsafetyfirst.org.uk and search best practice.

25.0 Servicing and maintenance

ANNUAL MAINTENANCE should be performed by a competent operative.

A maintenance record should be kept on the service record on page 33 of this booklet.

25.1 Annual service checks

- **Expansion relief valve** - manually open the twist cap and check that the water is discharged and runs clearly through the Tundish and out at the final discharge point. Ensure that the valve re-seats/re-seals itself.
- **Pressure & temperature relief valve** - repeat the above procedure. Ensure that the valve re-seats/re-seals itself.
- **Strainer** - turn off mains at stopcock. There will be a small amount of residual water in the pipework, remove the cartridge from Pressure Reducing Valve, clean Strainer and replace.
- **Expansion vessel** - check pressure via the valve on top of the vessel which is located under the plastic cap. Ensure pressure is 3 Bar. Vessel can be recharged if required as per 'Expansion vessel check and re-charging' on page 27.

25.2 Disassociating an account

If a new tenant is moving into the property and the user of the account tied to the cylinder needs to be changed, the new tenant will have to disassociate the cylinder from the existing account before registering. This can be performed by pressing and holding the boost down and power buttons for approximately 15 seconds.

25.3 De-scaling

Occasionally, the Mixergy iHP may need the heat pump heat exchanger de-scaling.

1. To de-scale the unit, switch off the supply and drain the cylinder to below the lower end of the head unit feed flexi (1).
2. Disconnect the two flexi hoses from the heat pump unit.
3. Connect a reservoir and pump to the heat pump connections (2) and (3).
4. Pump de-scaling fluid through the heat exchanger for an hour.
5. Drain the de-scaling fluid from the heat exchanger and flush with water for a further 5 minutes to ensure all the de-scaling fluid has been removed.
6. Disconnect the reservoir and pump.
7. Reconnect the two flexi hoses disconnected in step 2 and re-fill the cylinder.
8. Bleed and test the system as described in "Commissioning" on page 36
9. The de-scaling procedure is now complete.

25.0 Servicing and maintenance



After descaling, it the responsibility of the installer to ensure ensure proper functionality of the iHP.

1. Head unit feed flexi hose
2. Heat pump return connector
3. Heat pump feed connector

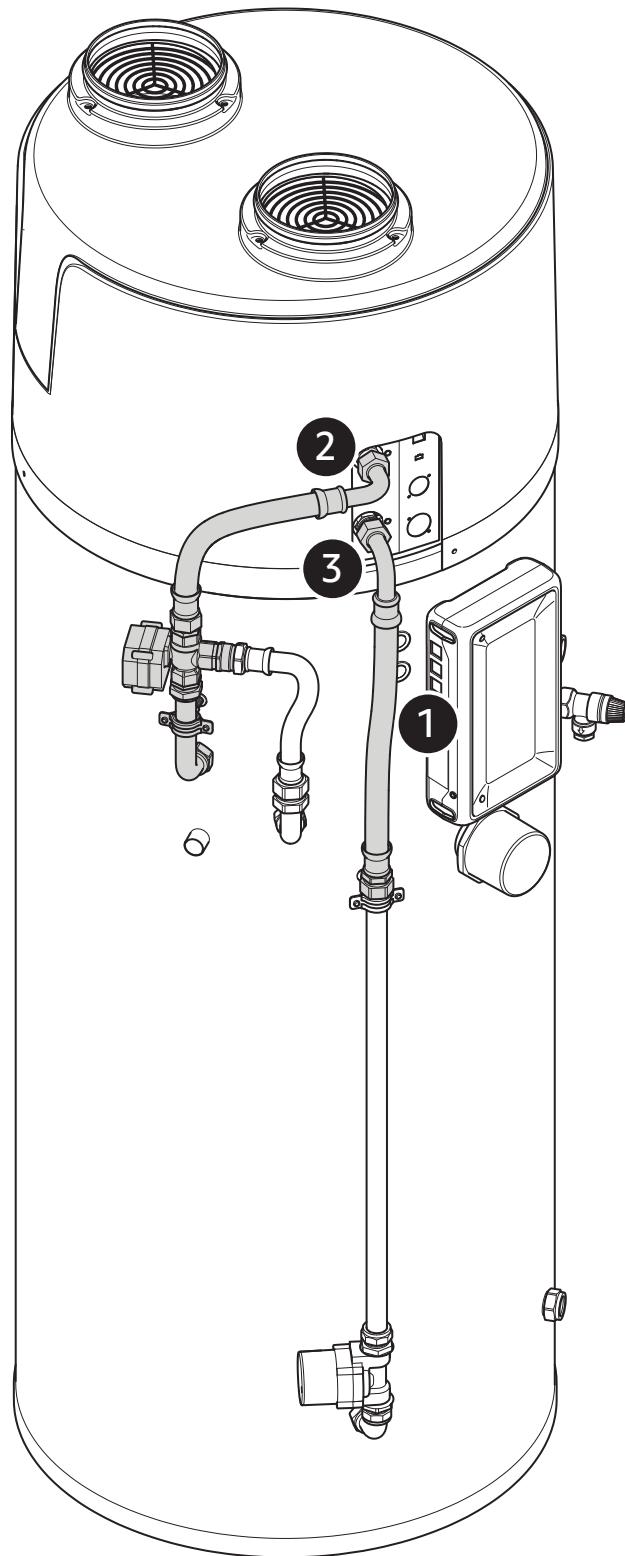

Fig. 41

26.0 Service Record

It is recommended that your hot water system is serviced regularly and that the appropriate service record is completed.

Before completing the service record below, please ensure you have completed the service in accordance with the manufacturer's instructions.

Service No.1	Date		Service No.2	Date	
Engineer name			Engineer name		
Company name			Company name		
Telephone No.			Telephone No.		
Email address			Email address		
Comments			Comments		
Signature			Signature		
Service No.3	Date		Service No.4	Date	
Engineer name			Engineer name		
Company name			Company name		
Telephone No.			Telephone No.		
Email address			Email address		
Comments			Comments		
Signature			Signature		

26.0 Service Record

Service No.5	Date		Service No.6	Date	
Engineer name			Engineer name		
Company name			Company name		
Telephone No.			Telephone No.		
Email address			Email address		
Comments			Comments		
Signature			Signature		
Service No.7	Date		Service No.8	Date	
Engineer name			Engineer name		
Company name			Company name		
Telephone No.			Telephone No.		
Email address			Email address		
Comments			Comments		
Signature			Signature		
Service No.9	Date		Service No.10	Date	
Engineer name			Engineer name		
Company name			Company name		
Telephone No.			Telephone No.		
Email address			Email address		
Comments			Comments		
Signature			Signature		

26.0 Service Record

Service No.11	Date		Service No.12	Date	
Engineer name			Engineer name		
Company name			Company name		
Telephone No.			Telephone No.		
Email address			Email address		
Comments			Comments		
Signature			Signature		
Service No.13	Date		Service No.14	Date	
Engineer name			Engineer name		
Company name			Company name		
Telephone No.			Telephone No.		
Email address			Email address		
Comments			Comments		
Signature			Signature		
Service No.15	Date		Service No.16	Date	
Engineer name			Engineer name		
Company name			Company name		
Telephone No.			Telephone No.		
Email address			Email address		
Comments			Comments		
Signature			Signature		

26.0 Service Record

Service No.17	Date		Service No.18	Date	
Engineer name			Engineer name		
Company name			Company name		
Telephone No.			Telephone No.		
Email address			Email address		
Comments			Comments		
Signature			Signature		
Service No.19	Date		Service No.20	Date	
Engineer name			Engineer name		
Company name			Company name		
Telephone No.			Telephone No.		
Email address			Email address		
Comments			Comments		
Signature			Signature		
Service No.21	Date		Service No.22	Date	
Engineer name			Engineer name		
Company name			Company name		
Telephone No.			Telephone No.		
Email address			Email address		
Comments			Comments		
Signature			Signature		

26.0 Service Record

Service No.23	Date		Service No.24	Date	
Engineer name			Engineer name		
Company name			Company name		
Telephone No.			Telephone No.		
Email address			Email address		
Comments			Comments		
Signature			Signature		
Service No.25	Date		Service No.26	Date	
Engineer name			Engineer name		
Company name			Company name		
Telephone No.			Telephone No.		
Email address			Email address		
Comments			Comments		
Signature			Signature		
Service No.27	Date		Service No.28	Date	
Engineer name			Engineer name		
Company name			Company name		
Telephone No.			Telephone No.		
Email address			Email address		
Comments			Comments		
Signature			Signature		

For further guidance and troubleshooting
visit **support.mixergy.co.uk**

mixergy[®]

www.mixergy.co.uk

Mixergy Ltd, 2 Canal View, Wharf Farm, Eynsham
Road, Cassington, Oxfordshire OX29 4DB

Issue 1 02/26 MDC0031-06